

5905, 5910, 5915 SERIE

Vertikal-Kniehebelspanner | Produktübersicht

Produktmerkmale:

- Massiver, geschmiedeter Spannarm für hohe Festigkeit bei Schwerlast-Applikationen
- Hohe Lebensdauer durch gehärtete Bolzen und Buchsen
- Oberfläche brüniert
- Großer Freiraum unter dem Spannarm

Anwendungsbereiche:

- Schweißen
- Montieren



5905/5910/5915
Fuß abgewinkelt



5905-B/5910-B
Massiver Fuß
zum Anschweißen



Technische Daten

Modell	Max. Haltekraft	Spannarm Öffnungswinkel (+10°)	Handgriff Öffnungswinkel (+10°)	Gewicht
5905	[750lbf.] 3340N	135°	70°	[1.08lbs] 0,49kg
5905-B				[0.82lbs] 0,37kg
5910	[1600lbf.] 7120N	132°	71°	[2.84lbs] 1,29kg
5910-B				[2.24lbs] 1,02kg
5915	[2750lbf.] 12230N	147°	74°	[6.16lbs] 2,79kg
5915-B	[2750lbf.] 12230N	147°	74°	[5.11lbs] 2.32kg



Optionale Öffnungswinkelbegrenzung bei 90° durch austauschbaren Anschlag

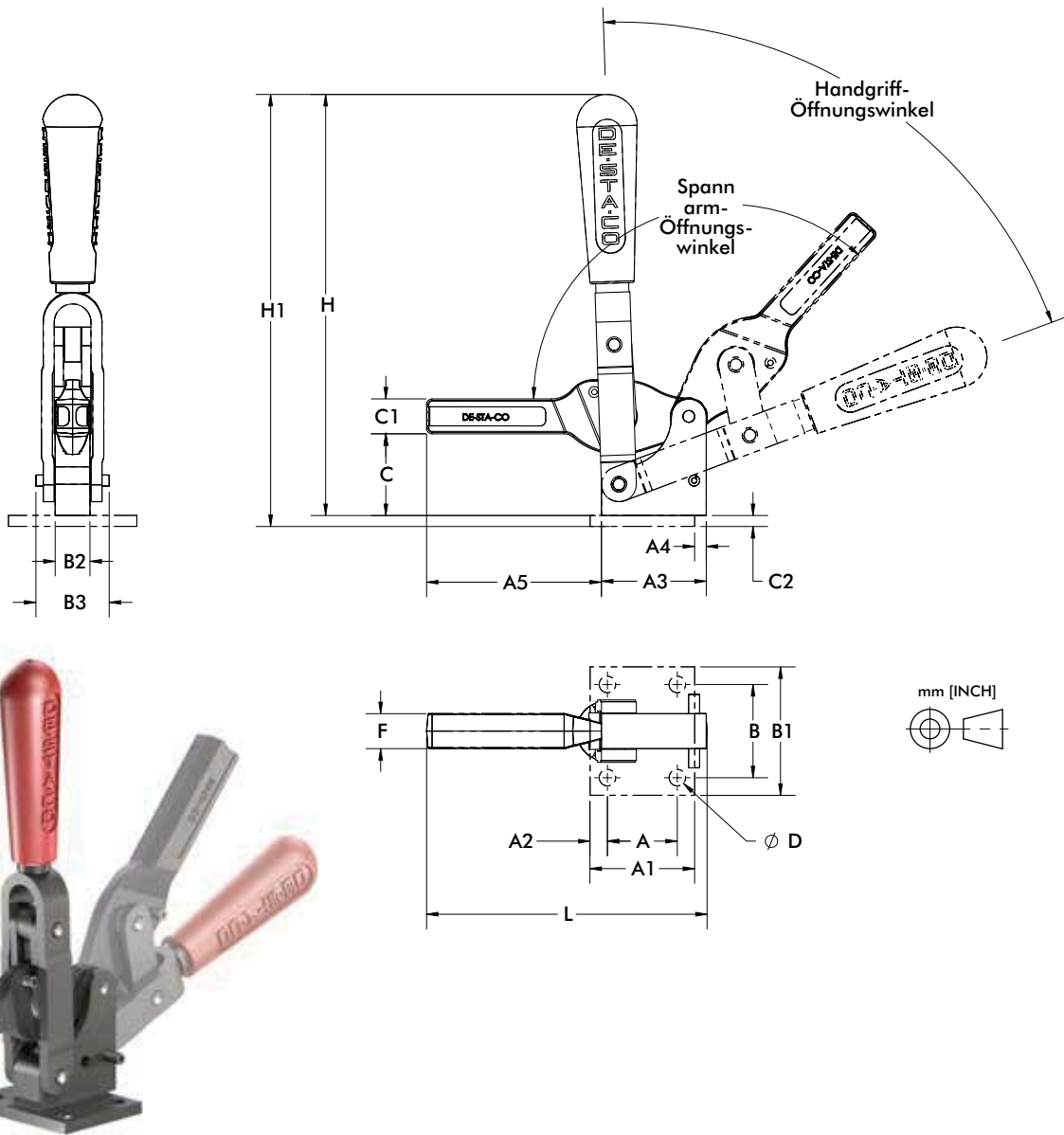

Modell	A	A1	A2	A3	A4	A5	B	B1	B2	B3	C	C1	C2	D	F	H	H1	L
5905	[1.00] 25,4	[1.50] 38,1	[0.25] 6,4	[1.51] 38,4	[0.25] 6,4	[2.49] 63,2	[1.50] 38,1	[2.13] 54,1	[0.59] 15,0	[1.02] 25,9	[1.27] 32,3	[0.51] 12,9	[0.24] 6,1	[0.29] 7,3	[0.56] 14,2	[6.51] 165,4	[6.75] 171,4	[4.02] 102,10
5910	[1.50] 38,1	[2.24] 56,9	[0.37] 9,4	[2.25] 57,2	[0.25] 6,4	[3.76] 95,5	[2.00] 50,8	[2.76] 70,1	[0.75] 19,1	[1.57] 39,9	[1.75] 44,5	[0.75] 19,1	[0.24] 6,1	[0.41] 10,5	[0.75] 19,1	[9.04] 229,5	[9.27] 235,5	[6.02] 152,88
5915	[2.00] 50,8	[2.95] 74,9	[0.48] 12,2	[2.99] 75,9	[0.38] 9,7	[5.00] 127,0	[2.75] 69,9	[3.88] 98,6	[0.98] 24,9	[1.97] 50,0	[2.37] 60,2	[1.00] 25,4	[0.35] 8,9	[0.55] 14,0	[1.00] 25,4	[10.89] 276,7	[11.25] 285,7	[7.50] 190,50

Modell	A3	A5	B2	B3
5905-B	[1.51] 38,4	[2.49] 63,2	[0.59] 15,0	[1.02] 25,9
5910-B	[2.25] 57,2	[3.76] 95,5	[0.75] 19,1	[1.57] 39,9
5915-B	[2.99] 76	[4.92] 125	[0.98] 25	[1.97] 50