

## Artikelbeschreibung/Produktabbildungen

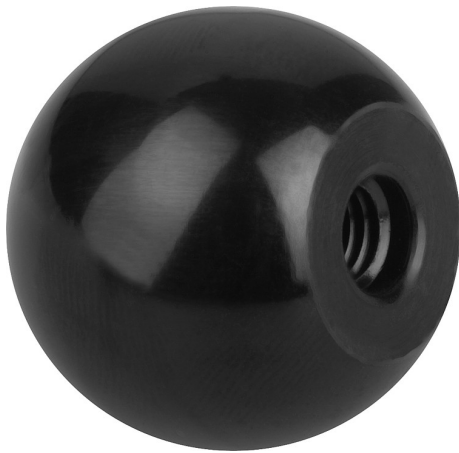

### Beschreibung

**Werkstoff:**

Duroplast PF 31, schwarz. Buchse aus Stahl, verzinkt.

**Ausführung:**

entgratet und hochglanzpoliert.

## Zeichnungen

Form C  
mit Pressstoffgewinde

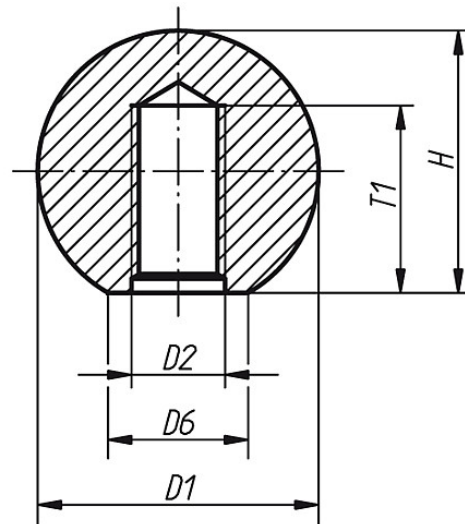

## Artikelübersicht

Bestellnummer	Form	D1	D2	~D6	~H	T1 min.
K0159.11604	C	16	M4	8	15	7
K0159.11605	C	16	M5	8	15	7,5
K0159.11606	C	16	M6	8	15	7,5
K0159.12005*	C	20	M5	12	18	9
K0159.12006	C	20	M6	12	18	10,5
K0159.12506*	C	25	M6	15	23	11
K0159.12508	C	25	M8	15	23	13,5
K0159.13008*	C	30	M8	16	28	14
K0159.13208*	C	32	M8	18	29	14,5
K0159.13210	C	32	M10	18	29	16
K0159.13508*	C	36	M8	17	33	20
K0159.13510*	C	36	M10	17	33	21
K0159.14008	C	40	M8	20	37,5	22
K0159.14010*	C	40	M10	20	37,5	18
K0159.14012	C	40	M12	20	37,5	23

## Artikelübersicht

Bestellnummer	Form	D1	D2	~D6	~H	T1 min.
K0159.14510	C	45	M10	20	43	26
K0159.14512	C	45	M12	20	43	30
K0159.15010	C	50	M10	22	48	30
K0159.15012*	C	50	M12	22	48	21