

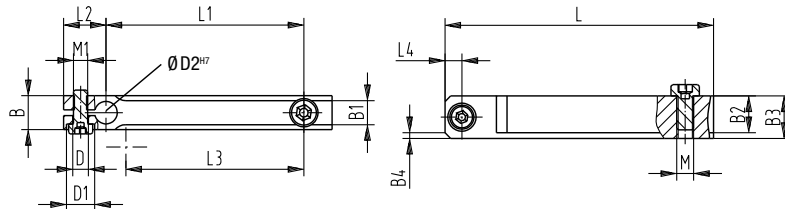

**Manuelle Spanntechnik Zubehör**

**Adapter und Verlängerungen**

**Verlängerungen**



Modell	Verlängerungen	B	B1 +0, -1	B2	B3	B4	DØ	D1 Ø	D2 <sup>H7</sup>	L	L1 ±0,2	L2	L3	L4	M	M1
<b>213-U-L / 213-UB-L</b>	<b>L-213-1-01</b> ⓘ	[0.39]	[0.22]	[0.31]	[0.39]	2x45°	[0.22]	--		[1.97]	[1.18]	[0.47]	[0.79]	[0.20]	M4	M5
<b>2013-U / 2013-UB</b>	<b>L-213-1-02</b> ⓘ	10	5,5	8	10		5,5			[3.54]	[2.76]	12	20	5		
<b>2013-UR / 2013-UBR</b>										90	70					
<b>202-U-L / 202-UB-L</b>	<b>L-217-1-01</b> ⓘ								[0.24]	[2.17]	[1.18]		[1.30]			
<b>217-U-L / 217-UB-L</b>									6	55	30		33			
<b>2002-U-L / 2002-UB-L</b>	<b>L-217-1-02</b> ⓘ		[0.26]	[0.35]	[0.47]	2x45°	[0.22]			[3.74]	[2.76]				M5	M5
<b>2017-U / 2017-UB</b>			6,5	9	12		5,5			95	70		[1.89]			
<b>2017-UR / 2017-UBR</b>	<b>L-217-1-03</b> ⓘ									[5.31]	[4.33]		48			
<b>2017-UR / 2017-UBR</b>										135	110					
<b>207-U-L / 207-UB-L</b>	<b>L-227-1-01</b> ⓘ	[0.47]						[0.39]		[2.17]	[1.18]	[0.59]	[1.30]	[0.24]		
<b>227-U-L / 227-UB-L</b>		12						10		55	30	15	33	6		
<b>2007-U-LS / 2007-UB-LS</b>	<b>L-227-1-02</b> ⓘ		[0.33]	[0.51]	[0.59]	2x45°	[0.22]		[0.31]	[3.74]	[2.76]				M6	M5
<b>2027-U / 2027-UB</b>			8,5	13	15		5,5		8	95	70					
<b>2027-UR / 2027-UBR</b>	<b>L-227-1-03</b> ⓘ									[5.31]	[4.33]		[2.87]			
<b>2027-UR / 2027-UBR</b>										135	110		73			
<b>2027-UR / 2027-UBR</b>	<b>L-227-1-04</b> ⓘ									[6.89]	[5.91]					
<b>2027-UR / 2027-UBR</b>										175	150					

ⓘ Lieferzeit auf Anfrage.

Auch in schwarz lieferbar. „-BLK“ hinzufügen.

**Höhenverstellung**

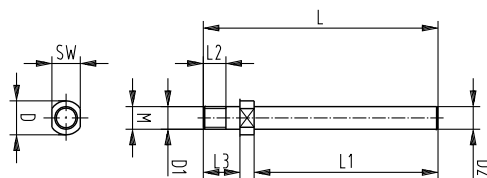

Modell	Höhenverstellung	DØ	D1 Ø f7	D2 f7	L	L1	L2	L3	SW	M
<b>213-U-L / 213-UB-L</b>	<b>L-213-2-01</b> ⓘ		[0.20]	[0.24]	[2.05]	[1.38]				M5
<b>2013-U / 2013-UB</b>			5	6	52	35				
<b>2013-UR / 2013-UBR</b>	<b>L-213-2-02</b> ⓘ				[3.23]	[2.56]				
<b>2013-UR / 2013-UBR</b>					82	65				
<b>202-U-L / 202-UB-L</b>		[0.39]			[2.05]	[1.38]		[0.47]	[0.31]	
<b>217-U-L / 217-UB-L</b>	<b>L-217-2-01</b> ⓘ	10			52	35		12	8	
<b>2002-U-LS / 2002-UB-LS</b>			[0.24]	[0.24]						M6
<b>2017-U / 2017-UB</b>	<b>L-217-2-02</b> ⓘ		6	6	[3.23]	[2.56]	[0.31]			
<b>2017-UR / 2017-UBR</b>					82	65	8			
<b>2017-UR / 2017-UBR</b>										
<b>207-U-L / 207-UB-L</b>					[2.09]	[1.38]				
<b>227-U-L / 227-UB-L</b>	<b>L-227-2-01</b> ⓘ		[0.31]	[0.31]	53	35		[0.51]	[0.39]	M8
<b>2007-U-LS / 2007-UB-LS</b>		[0.31]	8	88				13	10	
<b>2027-U / 2027-UB</b>	<b>L-227-2-02</b> ⓘ				[3.23]	[2.56]				
<b>2027-UR / 2027-UBR</b>					82	65				

ⓘ Lieferzeit auf Anfrage.

Auch in schwarz lieferbar. „-BLK“ hinzufügen.

**Manuelle Spanntechnik Zubehör**



**Adapter und Verlängerungen**

Spannarm-Adapter

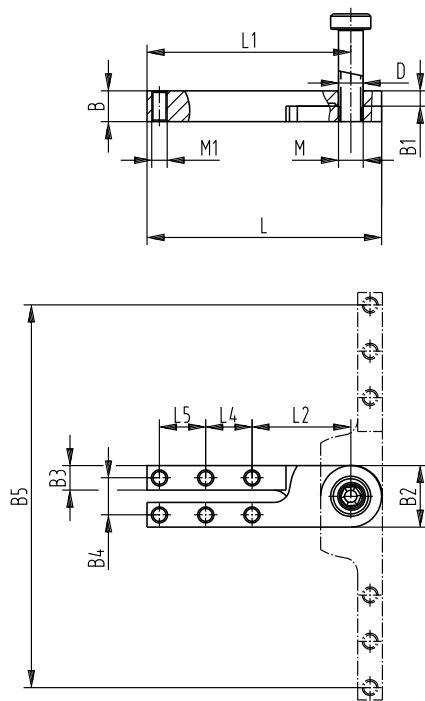

Modell	Spannarm Adapter	B	B1	B2	B3	B4	B5	DØ	L	L1	L2	L4	L5	L6	M	M1
213-U-L / 213-UB-L 2013-U / 2013-UB 2013-UR / 2013-UBR	L-213-3-01 ⓘ							[0.20] 5							M5	M5
202-U-L / 202-UB-L 217-U-L / 217-UB-L 2002-U-LS / 2002-UB-LS 2017-U / 2017-UB 2017-UR / 2017-UBR	L-217-3-01 ⓘ	[0.39] 10	[0.20] 5	[0.79] 20	[0.31] 8	[0.47] 12	[3.70] 94	[0.24] 6	[2.40] 61	[2.01] 51		[1.26] 32	[0.59] 15		[0.39] 10	M6 M5
207-U-L / 207-UB-L 227-U-L / 227-UB-L 2007-U-LS / 2007-UB-LS 2027-U / 2027-UB 2027-UR / 2027-UBR	L-227-3-01 ⓘ						4.88 124	[0.31] 8	[2.99] 76	[2.60] 66			[0.59] 15		M8	M5

ⓘ Lieferzeit auf Anfrage. Auch in schwarz lieferbar. „-BLK“ hinzufügen.



**Manuelle Spanntechnik Zubehör**

**Adapter und Verlängerungen**

**Verlängerungsleiste:**

- Einfaches Ablängen
- Mit Gewindebohrungen zur Aufnahme von Andruckspindeln

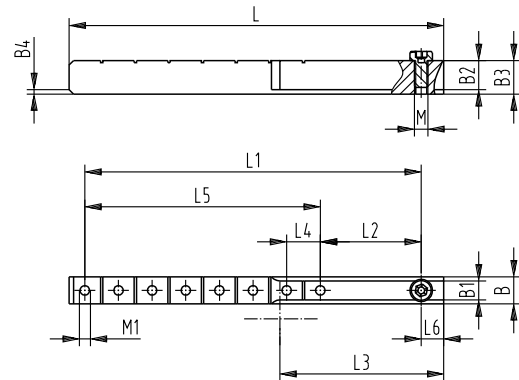

Modell	Verlängerungsleiste	B	B1 +0, -1	B2	B3	B4	L ±0,2	L1	L2	L3	L4	L5	L6	M	M1
213-U-L / 213-UB-L 2013-U / 2013-UB 2013-UR / 2013-UBR	L-213-4-01 ⓘ	[0.39] 10	[0.22] 5,5	[0.31] 8	[0.39] 10	2x 45°	[2.95] 75	[2.36] 60	[0.94] 24	[0.79] 20	[0.47] 12	[1.42] 36	[0.31] 8	M4	M5
202-U-L / 202-UB-L 217-U-L / 217-UB-L 2002-U-LS / 2002-UB-LS 2017-U / 2017-UB 2017-UR / 2017-UBR	L-217-4-01 ⓘ	[0.47] 12	[0.26] 6,5	[0.35] 9	[0.47] 12	2x 45°	[5.00] 127	[4.33] 110	[1.38] 35	[1.89] 48		[2.95] 75	[0.39] 10	M5	M5
207-U-L / 207-UB-L 227-U-L / 227-UB-L 2007-U-LS / 2007-UB-LS 2027-U / 2027-UB 2027-UR / 2027-UBR	L-227-4-01 ⓘ	[0.33] 8,5	[0.51] 13	[0.59] 15	2x 45°	[6.57] 167	[5.91] 150	[1.77] 45	[2.87] 73		[0.59] 15	[4.13] 105	[0.39] 10	M6	M5

ⓘ Lieferzeit auf Anfrage. Auch in schwarz lieferbar. „-BLK“ hinzufügen.

**Querarmset mit Spindeln**

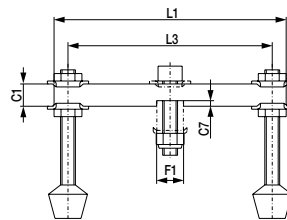

Modell	Für Modelle mit U-Arm	C1	C7	F	F1	L1	L3	Spindel empfohlen
207426-Q	207, 225, 227	[0.47] 12	[0.12] 3	[0.31] 35	[0.57] 14,5	[4.92] 125	[4.33] 110	507208-M
210440-Q	210, 235, 237	[0.63] 16	[0.16] 4	[0.43] 11	[0.75] 19	[5.87] 149	[5.12] 130	240208-M