

215 SERIES

Horizontal Hold Down Clamps | Product Overview

Features:

- Low profile
- Stainless steel model furnished without plastic grip

Applications:

- Assembly
- Checking fixtures
- Closures
- Woodworking

Also Available:

See page MC-ACC-1 for accessories
Accommodates M6 or 1/4" spindle accessory

215-U/USS Flanged Base U-Bar



215-UB ⓘ Straight Base U-Bar



215-S Flanged Base Solid Bar



Technical Information

Model	Max. Holding Capacity	Clamp Bar Opening (+10°)	Handle Opening (+10°)	Weight	Accessories (Supplied)		
					Spindle Assembly	Flanged Washers	Bolt Retainer
215-U	890 N [200 lbf]	87°	78°	[0.34 lb] 0,15 kg	202208-M	215105	--
215-USS	1110 N [250 lbf]				202943-M	215905	
215-UB ⓘ	[200 lbf] 890 N				202208-M	215105	
215-S					--	--	205105

ⓘ This item is available upon request

Holding Capacities

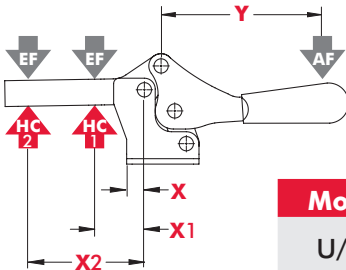

Model	X	X1	X2	Y	‡HC1	‡HC2	‡EF(X1):AF	‡EF(X2):AF
U/UB		[1.00] 25,4	[2.25] 57		[200 lbf] 890 N	[80 lbf] 360 N	9:1	4:1
USS	[0.22] 5,6			[2.72] 69	[250 lbf] 1110 N	[110 lbf] 490 N		
S		[1.63] 41,4	[2.88] 73		[200 lbf] 890 N		6:1	

Dimensions shown "mm [inch]" ‡ HC = Holding Capacity, EF = Exerting Force, AF = Applied Force
See page MC-TEC-4 for additional information.

215-U
Flanged Base
U-Bar

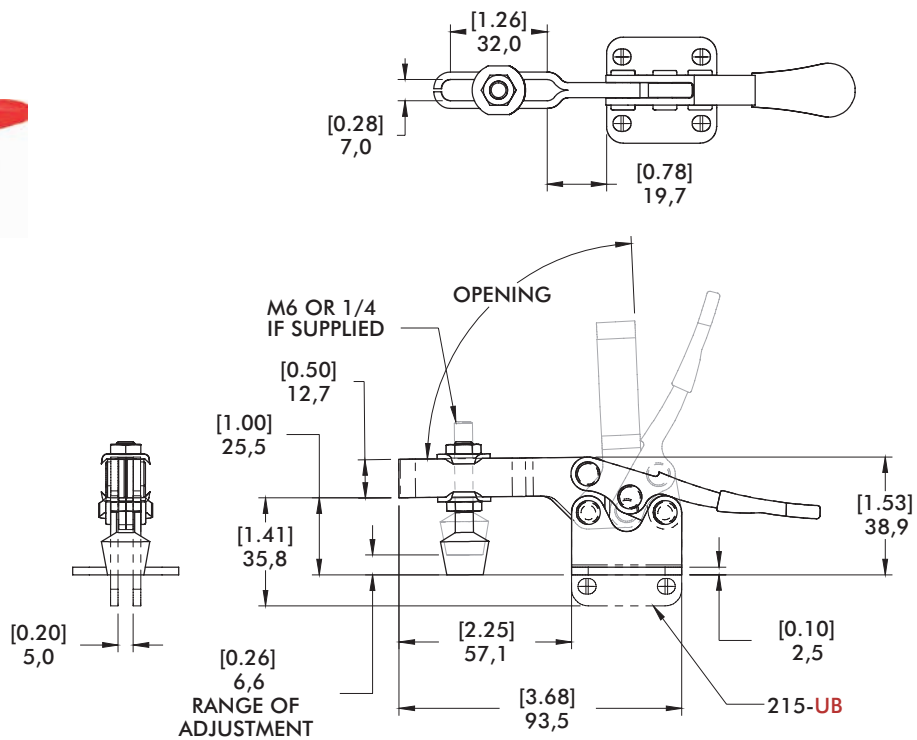

215-S
Flanged Base
Solid Bar

