

Klemmhebel, vertstellbare, Zink-Druckguß, Innengewinde, Axiallager

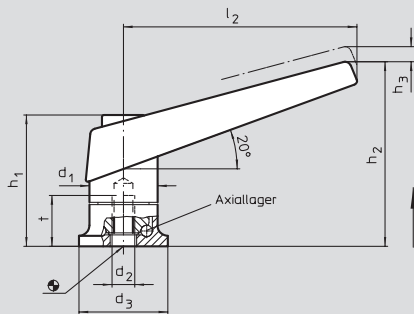

Verstellbare Klemmhebel

Ausrasten durch ZIEHEN
mit Axiallager

Ausführung:
Griffkörper aus Zink-Druckguß
Innenteil: Vergütungsstahl, nitriert,
schwarz

Form B: schwarz RAL 9005

Form C: orange RAL 2004





Nr. 02 122

Bestellbeispiel

02122.C1M06

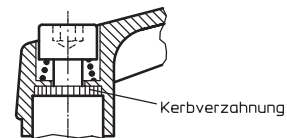
Form C
Größe 1
d 2 M 06



Größe	d ₁	d ₂	d ₃	h ₁	h ₂	h ₃	l ₂	t	 g
1	18	M 6	24,0	34,5	50	3,0	62	14,5	86
2	22	M 8	25,0	39,5	56	3,5	74	15,0	130
3	25	M 10	30,0	46,5	66	4,0	89	19,0	202
4	30	M 12	35,0	56,5	82	5,0	108	28,5	285