





## Modell 207-UF

Modell-Nr.	Haltekraft [N]	Öffnungs- winkel  +10°	 [kg]	 serienmäßig	 Flankenscheibe serienmäßig
207-UF	1.700	90°	0,94	225208-M	507107-M
207-UF-LS				ohne Andruckspindel	507107-M

Siehe Zubehör ab Seite 10.1

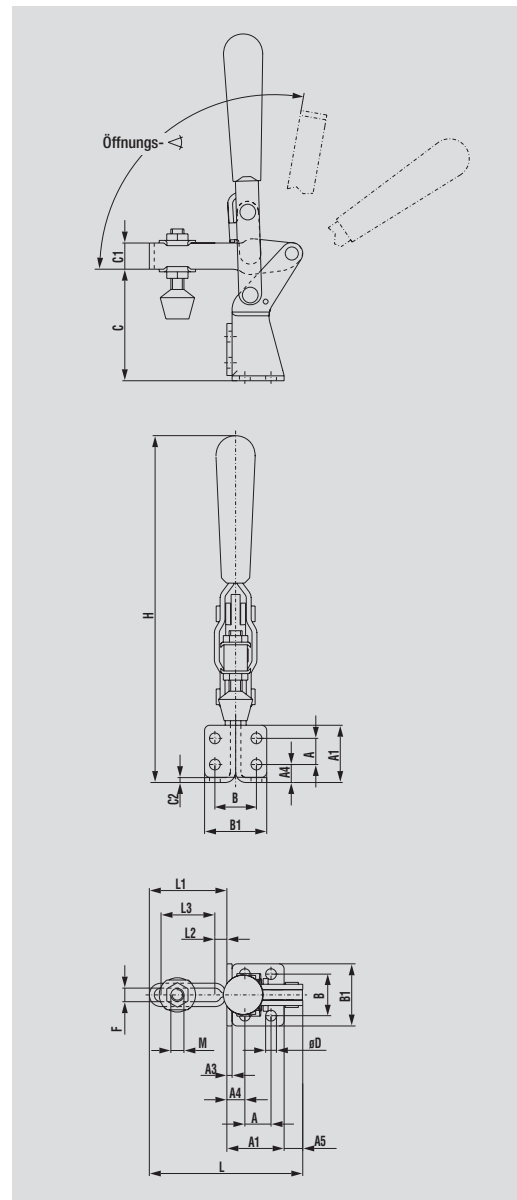

Modell-Nr.	A	A1	A3	A4	A5	B	B1	C	C1	C2	ØD	F	H	L	L1	L2	L3	M			
207-UF ▲	16,0	35,1	3,0	11,2	11,4	25,4	38,1	68,1	16,0	3,0	6,9	8,6	214,6	93,7	47,2	7,1	33,0	M8			

▲ Lieferzeit auf Anfrage