





## Modell 317-U

Modell-Nr.	Haltekraft [N]	Öffnungs- winkel  +10°	 [kg]	 serienmäßig 507208-M	 Flankenscheibe serienmäßig 507107-M
317-U	1.700	185°	0.75	507208-M	507107-M
317-U-LS				ohne Andruckspindel	507107-M

### Ebenfalls lieferbar

Als Standard-Kraftspanner Modell 817-UE Seite 12.15

Siehe Zubehör ab Seite 10.1

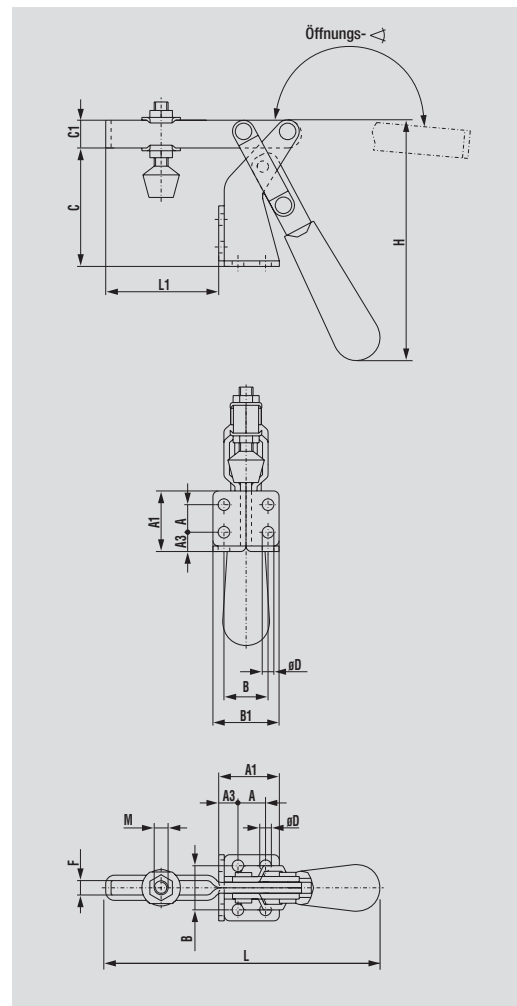

Modell-Nr.	A	A1	A3	B	B1	C	C1	ØD	F	H	L	L1	L2	L3	M
317-U	16,0	35,1	11,2	25,4	38,1	68,1	16,0	6,9	8,6	134,1	165,9	64,3	7,1	50,0	M8