

Abstützelement für Spanneisen

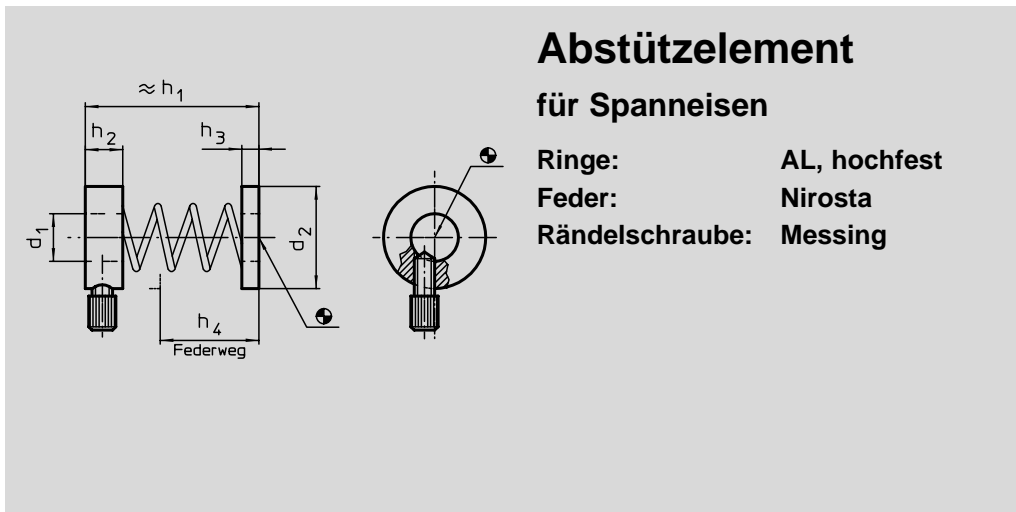

Abstützelement für Spanneisen

Ringe: AL, hochfest
 Feder: Nirosta
 Rändelschraube: Messing



Nr. 12 185

Bestellbeispiel:

12185.14

d₁ 14



d ₁	d ₂	h ₁	h ₂	h ₃	h ₄	für Schraube	 g
8,5	24	35	11	5	14	M 6 - M 8	25
14,0	28	51	11	5	29	M 10 - M 12	30
16,5	35	60	12	5	35	M 16	40