

# Spanneisen, abgeflachte Kugel

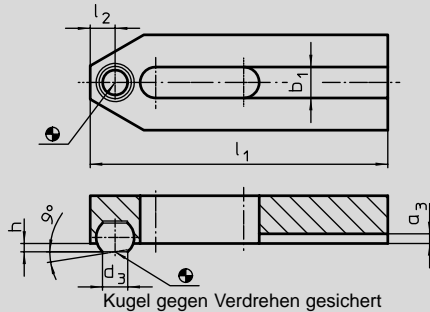

## Spanneisen

mit abgeflachter Kugel

Spanneisen: Vergütungsstahl,  
brüniert

Kugel: Kugellagerstahl  
gehärtet, blank



Nr. 12 135

Bestellbeispiel:

12135.07X050

b 1 7  
l 1 50

b <sub>1</sub>	l <sub>1</sub>	d <sub>3</sub>	a <sub>3</sub>	h	l <sub>2</sub>	Kugel Ø	 g
7	50	5,8	2,5	1,6	5,0	8,5	60
9	60	7,2	3,0	2,0	6,5	10,0	110
11	80	8,6	3,5	2,7	7,5	12,0	220
13	125	10,5	4,0	3,5	10,5	16,0	600

