

◀ **Nr. 05 110**

**Bestellbeispiel**  
05110.KD6

**Form**      **KD**  
**d 1**        **6**



## Federnde Druckstücke glatte Ausführung

**Werkstoffe:**

**Hülse:** NIROSTA 1.4303, Messing  
Delrin blau (POM)

**Kugel:** NIROSTA gehärtet  
Delrin weiß (POM)

**Feder:** NIROSTA

**Hinweis:**

Zur Arretierung sowie als An- und Abdruckstifte.

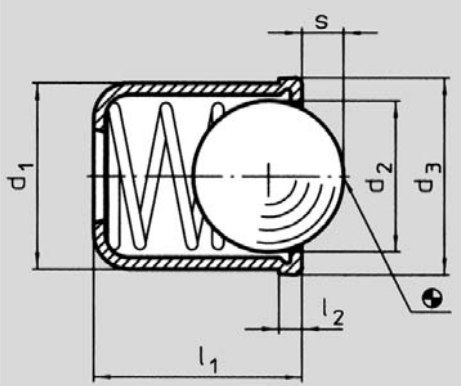

Form	Ausführung	d <sub>1</sub> +0,1	d <sub>2</sub>	d <sub>3</sub>	l <sub>1</sub>	l <sub>2</sub>	s	Federkraft*		max. °C	g
								F <sub>1</sub> N <sub>≈</sub>	F <sub>2</sub> F <sub>≈</sub>		
<b>B</b>	Hülse und	4	3,0	4,6	5,0	1	0,8	2,5	6,0	+ 250	0,35
	Kugel aus	5	4,0	5,6	6,0	1	1,0	3,0	6,5	+ 250	0,60
	Nirosta	6	5,0	6,5	7,0	1	1,6	5,5	11,5	+ 250	1,00
		8	6,5	8,5	9,0	1	1,9	7,0	12,5	+ 250	2,20
		10	8,5	11,0	13,5	1	3,1	8,5	18,5	+ 250	5,30
		12	10,0	13,0	16,0	1	3,8	12,0	26,5	+ 250	7,80
<b>MS</b>	Hülse aus	4	2,5	4,5	5,0	1	0,8	2,5	6,0	+ 250	0,45
	Messing	5	3,5	5,5	6,0	1	1,0	3,0	6,5	+ 250	0,80
	Kugel aus	6	4,5	6,5	7,0	1	1,6	5,5	11,5	+ 250	1,30
	Nirosta	8	6,0	8,5	9,0	1	1,9	7,0	12,5	+ 250	2,90
<b>K</b>	Hülse aus	4	3,0	4,6	5,0	1	0,8	2,5	6,5	- 30/ +50	0,20
	Delrin	5	4,0	5,6	6,0	1	1,0	4,5	9,0	- 30/ +50	0,40
	Kugel aus	6	5,0	6,5	7,0	1	1,6	6,5	13,0	- 30/ +50	0,70
	Nirosta	8	6,5	8,5	9,0	1	1,9	8,0	18,0	- 30/ +50	1,50
<b>KD</b>	Hülse und	4	3,0	4,6	5,0	1	0,8	2,5	6,5	- 30/ +50	0,10
	Kugel aus	5	4,0	5,6	6,0	1	1,0	4,5	9,0	- 30/ +50	0,20
	Delrin	6	5,0	6,5	7,0	1	1,6	6,5	13,0	- 30/ +50	0,30
		8	6,5	8,5	9,0	1	1,9	8,0	18,0	- 30/ +50	0,55



Federnde Druckstücke werden  
speziell auf Federweg und Federkraft  
geprüft.

\*statistischer Mittelwert

