

Artikelbeschreibung/Produktabbildungen



Beschreibung

Zeichnungen

Form C  
Riffelfläche

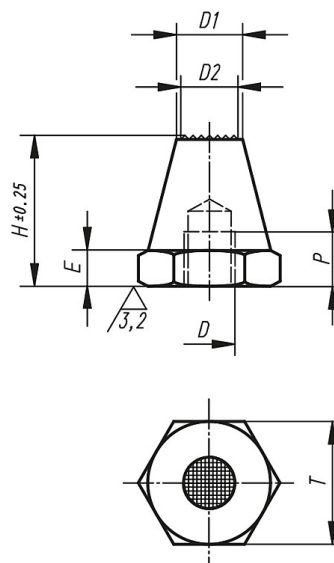

Artikelübersicht

Bestellnummer	Form	D	D1	D2	E	H	P	T	Gewicht ca. kg
K0294.306012	C	M6	6	5	3	12,5	4	11	0,005
K0294.306025	C	M6	6	5	3	25	7	11	0,008
K0294.308015	C	M8	8	6	4	15	6	13	0,009
K0294.308030	C	M8	8	6	4	30	9	13	0,018
K0294.310020	C	M10	10	8	5	20	9	17	0,017
K0294.310040	C	M10	10	8	5	40	13	17	0,035
K0294.312025	C	M12	12	9,5	6	25	11	19	0,025
K0294.312050	C	M12	12	9,5	6	50	16	19	0,062
K0294.316030	C	M16	16	13	8	30	12	24	0,050

## Artikelübersicht

Bestellnummer	Form	D	D1	D2	E	H	P	T	Gewicht ca. kg
K0294.316060	C	M16	16	13	8	60	20	24	0,112