

## Accelerate® Tooling Collection | Configuration Types

### SGM - Split Saddle Tooling 30mm Interpress Crossbar Tooling

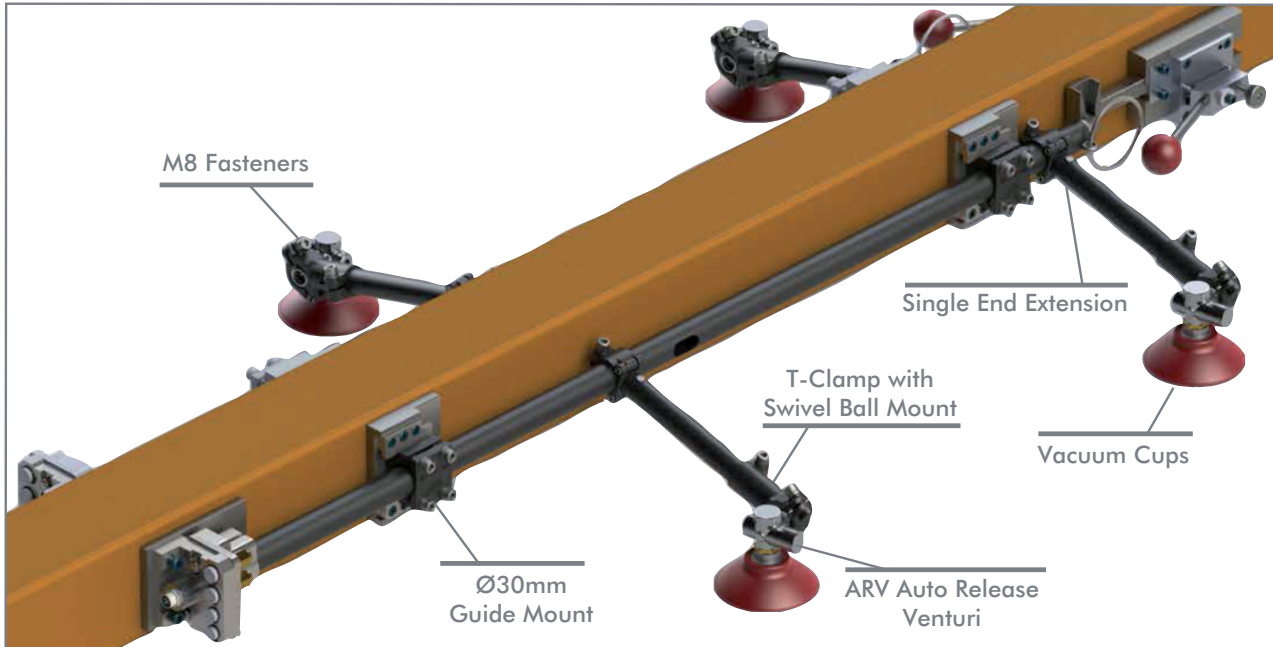

Model Number	Description
CPI-SGM-ASSY-FLC	Interpress Tool, Front Left Side, No Electric
CPI-SGM-ASSY-FRC	Interpress Tool, Front Right Side, No Electric
CPI-SGM-ASSY-RLC	Interpress Tool, Rear Left Side, No Electric
CPI-SGM-ASSY-RRC	Interpress Tool, Rear Right Side, No Electric
CPI-SGM-ASSY-FLC-EL	Interpress Tool, Front Left Side, w/Electric Connector Installed
CPI-SGM-ASSY-FRC-EL	Interpress Tool, Front Right Side, w/Electric Connector Installed
CPI-SGM-ASSY-RLC-EL	Interpress Tool, Rear Left Side, w/Electric Connector Installed
CPI-SGM-ASSY-RRC-EL	Interpress Tool, Rear Right Side, w/Electric Connector Installed



### SGM Blankload Crossbar Tooling

Model Number	Description
CPI-SGM-ASSY-BT-FL	Blankload Tool, Front Left Side, No Electric
CPI-SGM-ASSY-BT-FR	Blankload Tool, Front Right Side, No Electric
CPI-SGM-ASSY-BT-RL	Blankload Tool, Rear Left Side, No Electric
CPI-SGM-ASSY-BT-RR	Blankload Tool, Rear Right Side, No Electric
CPI-SGM-ASSY-BT-FL-EL	Blankload Tool, Front Left Side, w/Electric Connector Installed
CPI-SGM-ASSY-BT-FR-EL	Blankload Tool, Front Right Side, w/Electric Connector Installed
CPI-SGM-ASSY-BT-RL-EL	Blankload Tool, Rear Left Side, w/Electric Connector Installed
CPI-SGM-ASSY-BT-RR-EL	Blankload Tool, Rear Right Side, w/Electric Connector Installed

Dimensions and technical information are subject to change without notice