

## EH 23180.

### Spanneisen

mit Nase



Bild 1

Bild 2

#### Werkstoff:

- Vergütungsstahl, vergütet, brüniert

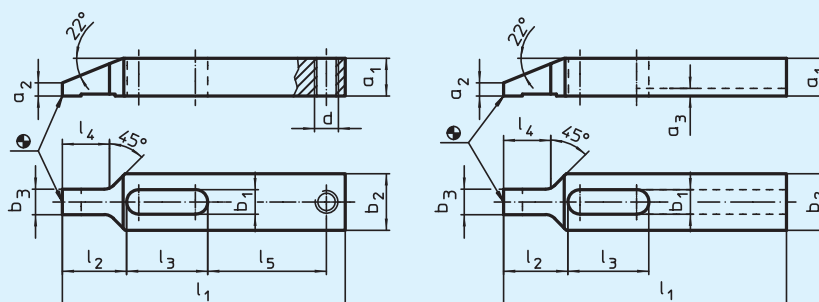
Best.-Nr.	Ausführung	Nenn- maß b <sub>1</sub>	l <sub>1</sub>	a <sub>1</sub>	a <sub>2</sub>	a <sub>3</sub>	b <sub>2</sub>	b <sub>3</sub>	d	l <sub>2</sub>	l <sub>3</sub>	l <sub>4</sub>	l <sub>5</sub>	g
23180.0107	mit Gewinde für	6,6	80	8	2,5	-	15	7,5	M 6	17	23	13	34	54
23180.0109	Stellschraube	9,0	100	12	4,0	-	20	9,5	M 8	22	29	17	42	134
23180.0111	(Bild 1)	11,0	125	15	5,0	-	25	11,5	M 10	28	36	21	52	263
23180.0113		13,0	150	20	7,0	-	30	13,5	M 12	34	43	25	63	504
23180.0117		17,0	175	25	9,0	-	35	15,5	M 16	40	52	29	70	828
23180.0207	mit Nut	6,6	80	8	2,5	2,5	15	7,5	-	17	23	13	34	50
23180.0209	(Bild 2)	9,0	100	12	4,0	3,0	20	9,5	-	22	29	17	42	127
23180.0211		11,0	125	15	5,0	3,5	25	11,5	-	28	36	21	52	251
23180.0213		13,0	150	20	7,0	4,0	30	13,5	-	34	43	25	63	488
23180.0217		17,0	175	25	9,0	4,5	35	15,5	-	40	52	29	70	812

