

Artikelbeschreibung/Produktabbildungen



Beschreibung

Werkstoff:

Hülse 1.4305.

Kugel 1.4034.

Feder 1.4310.

Ausführung:

blank. Kugel gehärtet.



Zeichnungen

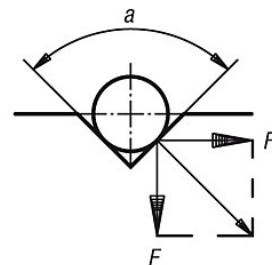
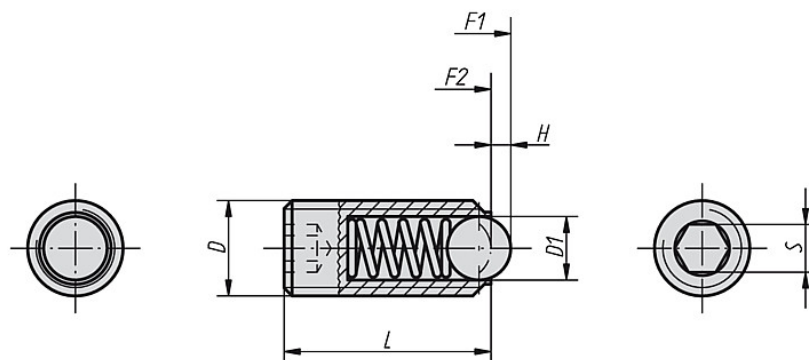

$a = 60^\circ, F' = 1.732 \times F$
 $a = 90^\circ, F' = F$
 $a = 120^\circ, F' = 0.577 \times F$

Artikelübersicht

Bestellnummer	D	D1	L	H	S	Federkraft Anfang F1 ca. N	Federkraft Ende F2 ca. N	Gewicht ca. g
K0316.203	M3	1,5	9	0,5	1,5	5	7	0,23
K0316.204	M4	2,5	10	0,8	2	12	22	0,46
K0316.205	M5	3	14	0,9	2,5	19	30	1,27
K0316.206	M6	3,5	15	1	3	28	40	2
K0316.208	M8	5	18	1,5	4	47	73	4
K0316.210	M10	6	23	2	5	66	100	8
K0316.212	M12	8	26	2,5	6	66	120	12
K0316.216	M16	10	33	3,5	8	90	180	31
K0316.220	M20	12	43	4,5	10	115	240	64
K0316.224	M24	15	48	5,5	12	130	270	100