

U-SPANNARME MITTIG (ALUMINIUM)

Geschlossene Handspanner | Abmessungen | Technische Informationen

52H-3E...50.. U-Spannarmer mittig

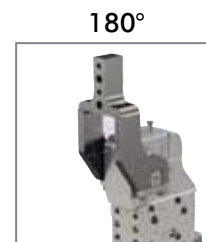
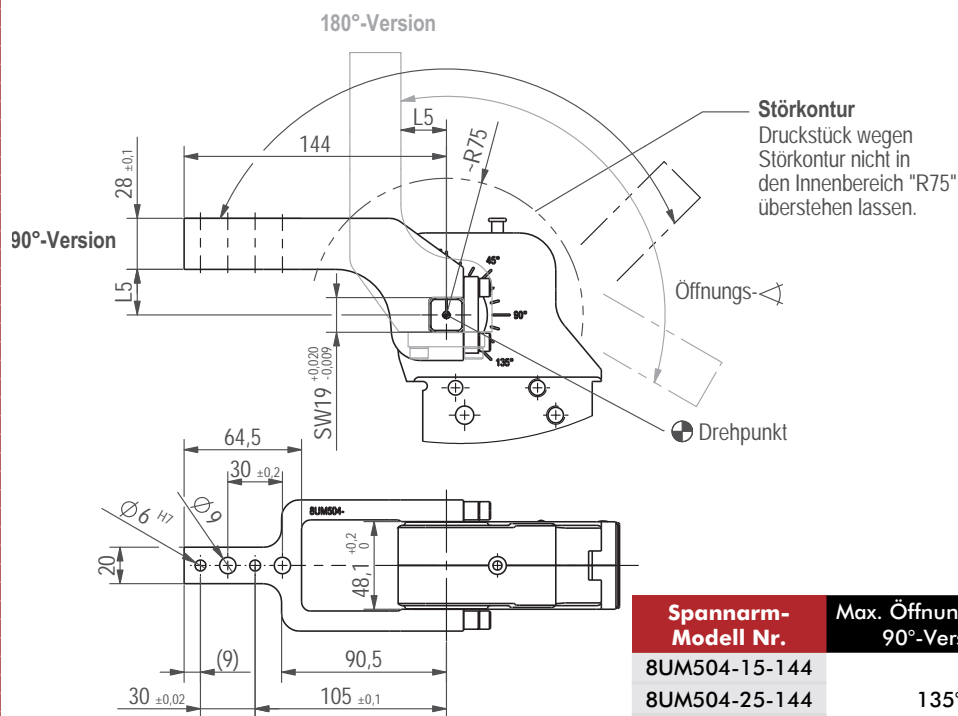

8UM504-15-144
8UM504-25-144
8UM504-45-144

Spannarm-Modell Nr.	Max. Öffnungswinkel 90°-Version	Max. Öffnungswinkel 180°-Version	Gewicht	L5
8UM504-15-144	135°	105°	0,44	15
8UM504-25-144		120°	0,45	25
8UM504-45-144		135°	0,48	45

52H-3.....63.. U-Spannarmer mittig

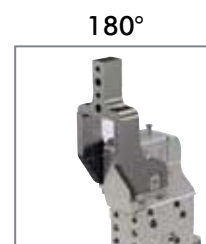
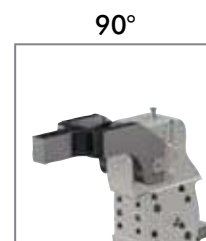
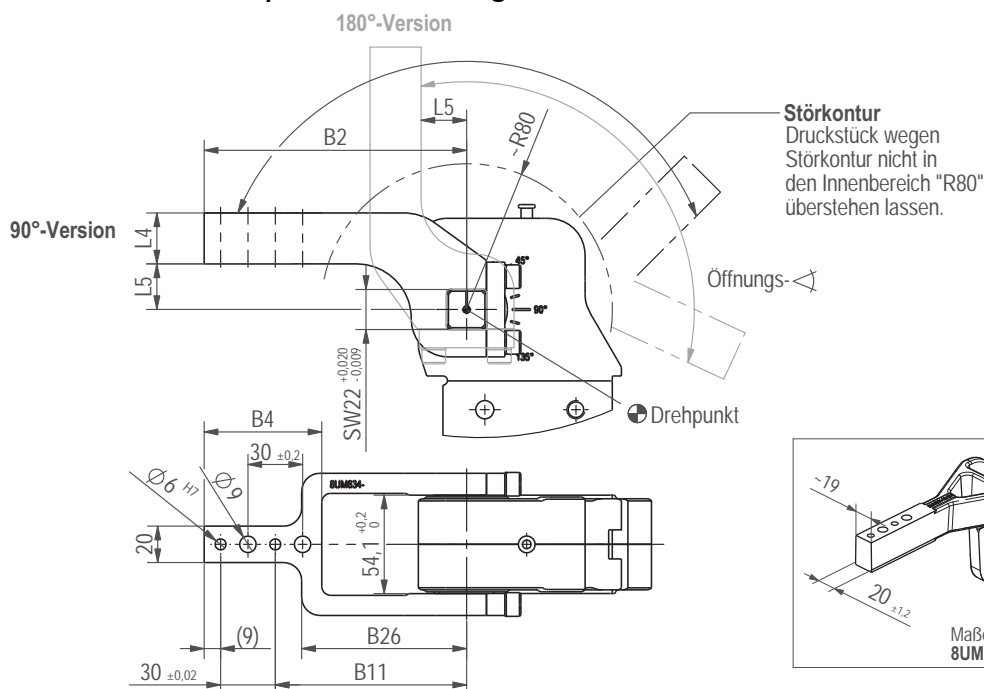

8UM634-15-144
8UM634-25-144
8UM634-45-144
*8UM631-75-204

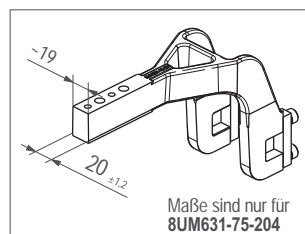

Spannarm-Modell Nr.	Max. Öffnungswinkel 90°-Version	Max. Öffnungswinkel 180°-Version	Gewicht	B2	B4	B11 $\pm 0,1$	B26	L4 $\pm 0,1$	L5
8UM634-15-144	135°	105°	0,50						15
8UM634-25-144		120°	0,53	144	64,5	105	90,5	28	25
8UM634-45-144		135°	0,56						45
*8UM631-75-204			1,7	204	82	165	107	30	75

* nur Stahlausführung lieferbar

U-SPANNARME, LINKS UND RECHTS (ALUMINIUM)

Geschlossene Handspanner | Abmessungen | Technische Informationen

52H-3E...50.. U-Spannarmer

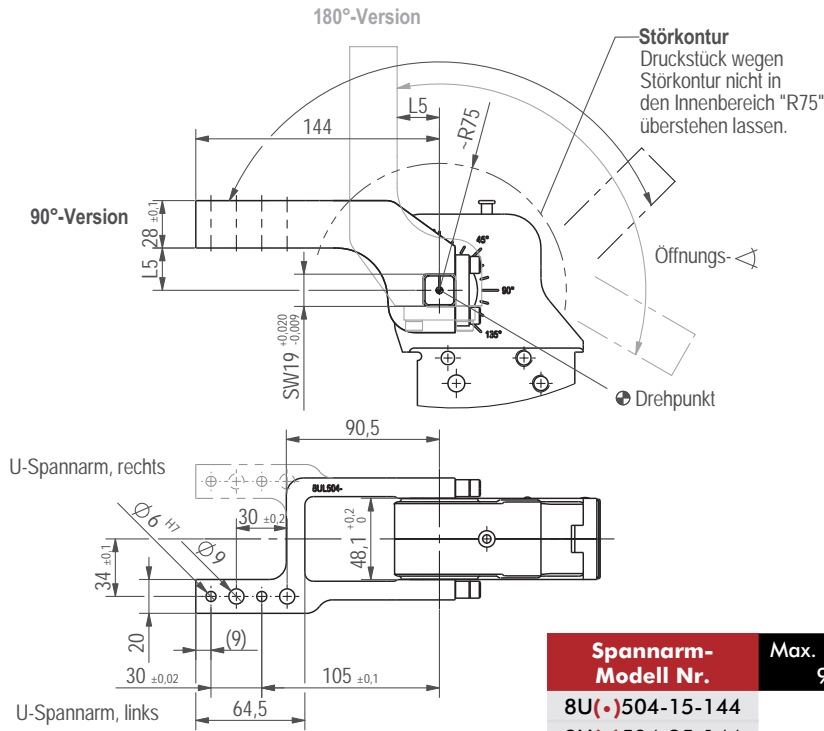

90° links

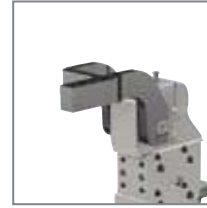

90° rechts



180° rechts*

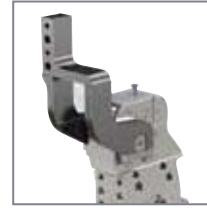

180° links*



8UL504-15-144
8UL504-25-144
8UL504-45-144

8UR504-15-144
8UR504-25-144
8UR504-45-144

*90° links/180° rechts sind die gleichen Spannarmermodelle.
90° rechts/180° links sind die gleichen Spannarmermodelle.

Spannarmer-Modell Nr.	Max. Öffnungswinkel 90°-Version	Max. Öffnungswinkel 180°-Version	Gewicht	L5
8U(•)504-15-144	135°	105°	0,45	15
8U(•)504-25-144		120°	0,46	25
8U(•)504-45-144		135°	0,49	45

52H-3.....63.. U-Spannarmer

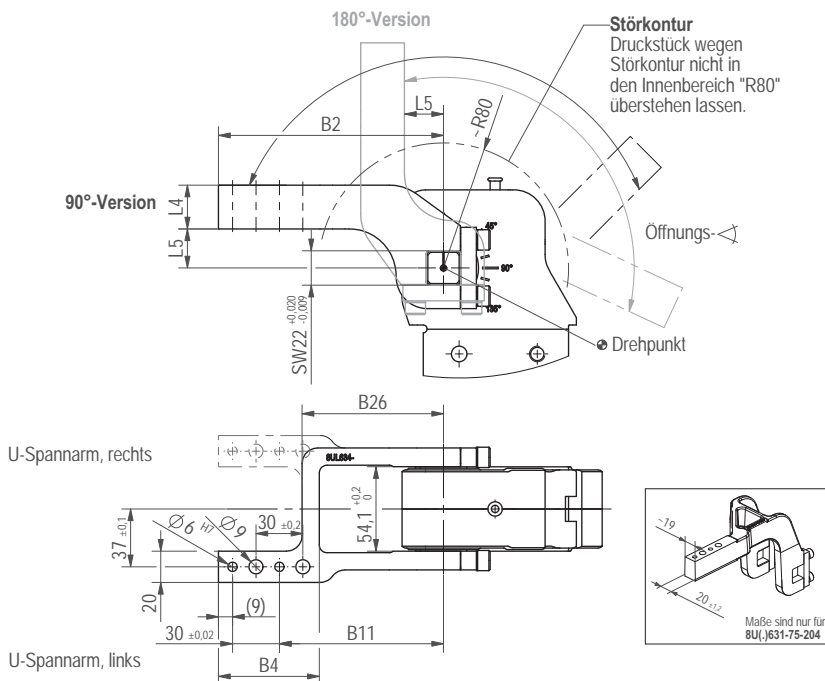

90° links



90° rechts



180° rechts*



180° links*



8UL634-15-144
8UL634-25-144
8UL634-45-144
**8UL631-75-204

8UR634-15-144
8UR634-25-144
8UR634-45-144
**8UR631-75-204

*90° links/180° rechts sind die gleichen Spannarmermodelle.
90° rechts/180° links sind die gleichen Spannarmermodelle.

Spannarmer-Modell Nr.	Max. Öffnungswinkel 90°-Version	Max. Öffnungswinkel 180°-Version	Gewicht	L5	B4	B11 ±0,1	B26	L4 ±0,1	L5
8U(•)634-15-144	135°	105°	0,52						15
8U(•)634-25-144		120°	0,54	144	64,5	105	90,5	28	25
8U(•)634-45-144		135°	0,58						45
**8U(•)631-75-204		135°	1,9	204	82	165	119	30	75

** nur Stahlausführung lieferbar

SPANNARME SEITLICH

Geschlossene Handspanner | Abmessungen | Technische Informationen

52H-3E....50..

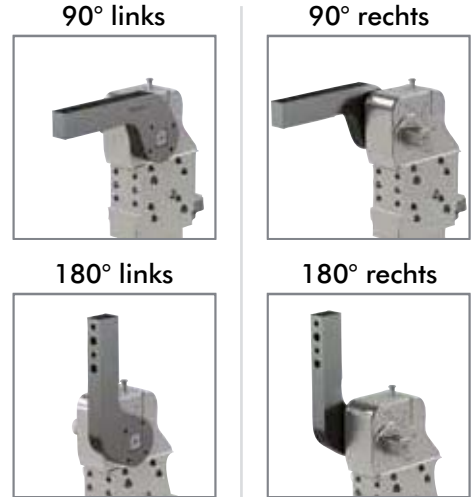
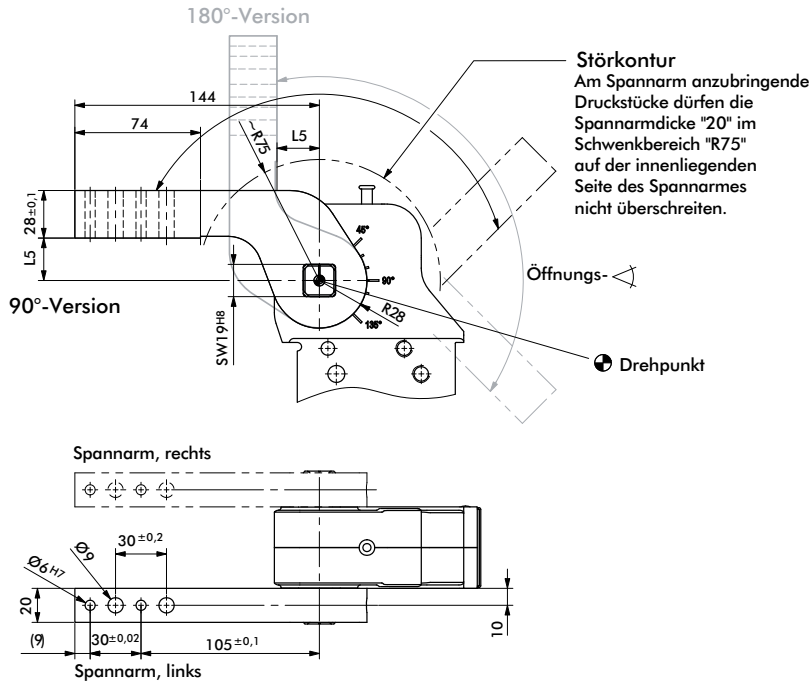

8JG-070-1-01
8S501-25-144

Spannarm-Modell Nr.	Max. Öffnungswinkel 90°-Version	Max. Öffnungswinkel 180°-Version	Gewicht	L5
8JG-070-1-01	135°	135°	0,9	15
8S501-25-144			1,0	25

Kraftspanner mit zwei seitlichen Spannarmen benötigen 2 Spannarmsets.

52H-3.....63..

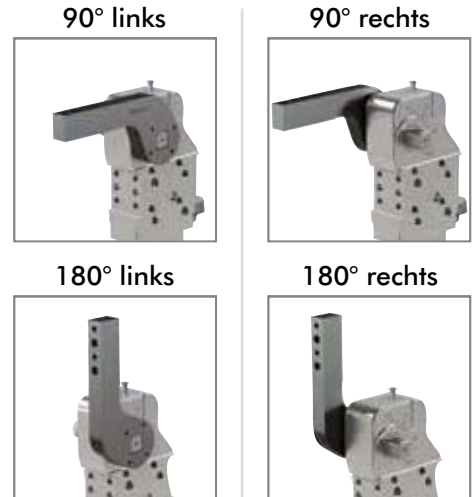
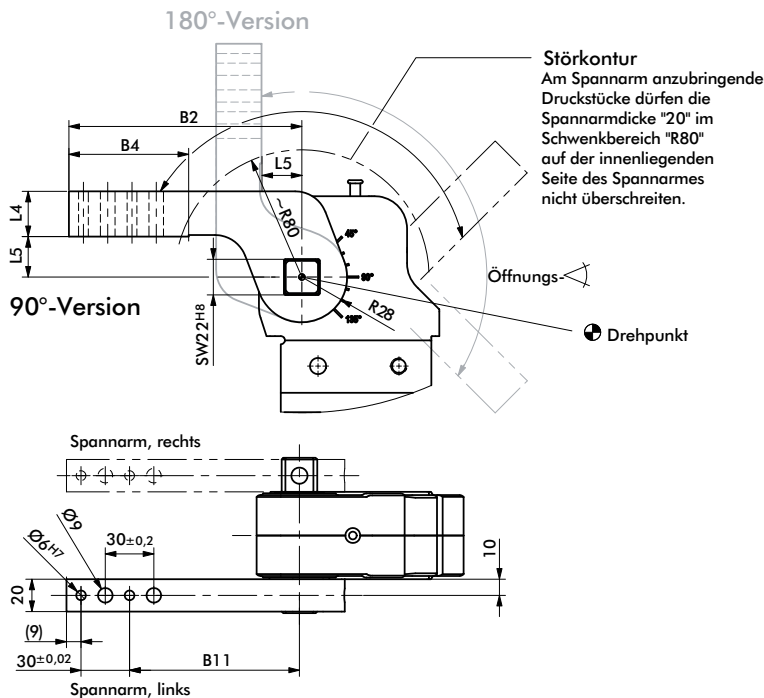

8JG-080-1-01
8S631-25-144
8S631-45-144
8S631-75-204

Spannarm-Modell Nr.	Max. Öffnungswinkel 90°-Version	Max. Öffnungswinkel 180°-Version	Gewicht (kg)	B2	B4	B11 ±0,1	L4 ±0,1	L5
8JG-080-1-01			0,9					15
8S631-25-144	135°	135°	1,0	144	74	105	28	25
8S631-45-144			1,1					45
8S631-75-204			1,5	204	78	165	30	75

Kraftspanner mit zwei seitlichen Spannarmen benötigen 2 Spannarmsets.

52H-3E. 50mm

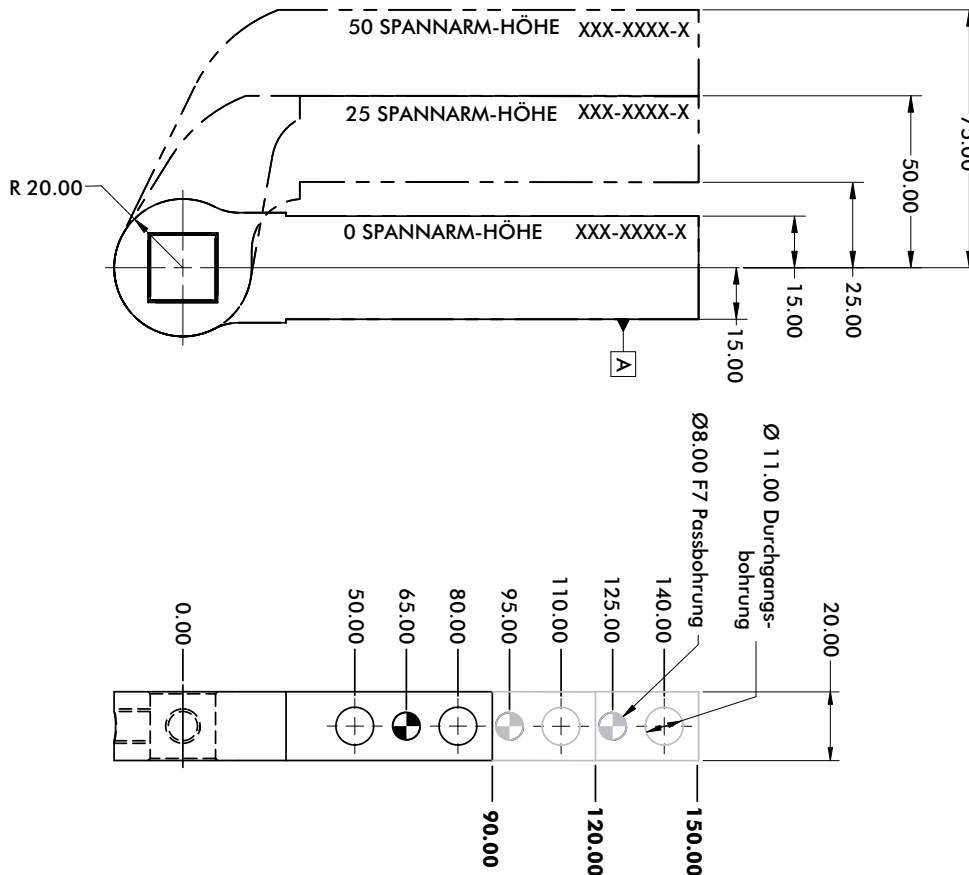

9 mm Durchgangslöcher (6 mm H7 Stiftloch)

90mm [3.54"] Spannarm-Länge

Serie	Spannarm-Variante	Modell
50 Spannarm-Höhe	▲ • 3256	B8JG-3256-1
25 Spannarm-Höhe	▲ • 3246	B8JG-3246-1
0 Spannarm-Höhe	▲ • 3236	B8JG-3236-1

120mm [4.72"] Spannarm-Länge

Serie	Spannarm-Variante	Modell
50 Spannarm-Höhe	▲ • 3257	B8JG-3257-1
25 Spannarm-Höhe	▲ • 3247	B8JG-3247-1
0 Spannarm-Höhe	▲ • 3237	B8JG-3237-1

150mm [5.90"] Spannarm-Länge

Serie	Spannarm-Variante	Modell
50 Spannarm-Höhe	▲ • 3258	B8JG-3258-1
25 Spannarm-Höhe	▲ • 3248	B8JG-3248-1
0 Spannarm-Höhe	▲ • 3238	B8JG-3238-1

11 mm Durchgangslöcher (8 mm F7 Stiftloch)

90mm [3.54"] Spannarm-Länge

Serie	Spannarm-Variante	Modell
50 Spannarm-Höhe	▲ • 1226	B8JG-1226-1
25 Spannarm-Höhe	▲ • 1216	B8JG-1216-1
0 Spannarm-Höhe	▲ • 1206	B8JG-1206-1

120mm [4.72"] Spannarm-Länge

Serie	Spannarm-Variante	Modell
50 Spannarm-Höhe	▲ • 1227	B8JG-1227-1
25 Spannarm-Höhe	▲ • 1217	B8JG-1217-1
0 Spannarm-Höhe	▲ • 1207	B8JG-1207-1

150mm [5.90"] Spannarm-Länge

Serie	Spannarm-Variante	Modell
50 Spannarm-Höhe	▲ • 1228	B8JG-1228-1
25 Spannarm-Höhe	▲ • 1218	B8JG-1218-1
0 Spannarm-Höhe	▲ • 1208	B8JG-1208-1

▲ Üblich in Nordamerika (•) STANDARD-ARM

Maximaler Öffnungswinkel (in geschlossener Position, wie abgebildet)

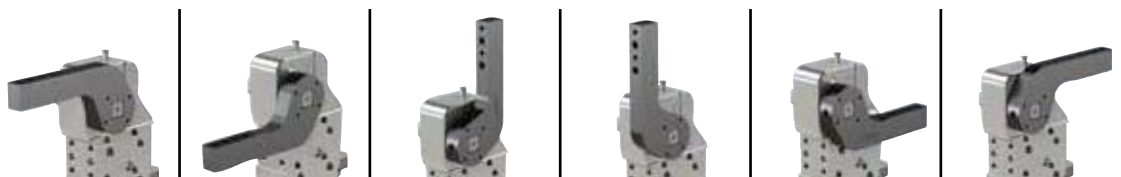

Spannarm-Varianten	1	2	3	4	5	6
1206-1208/3236-3238	135°	135°	100°	100°	N/A	N/A
1216-1218/3246-3248	135°	N/A	50°	125°	N/A	30°
1226-1228/3256-3258	125°	N/A	35°	135°	N/A	50°

52H-3E. 63mm für 23 Spannarmwelle

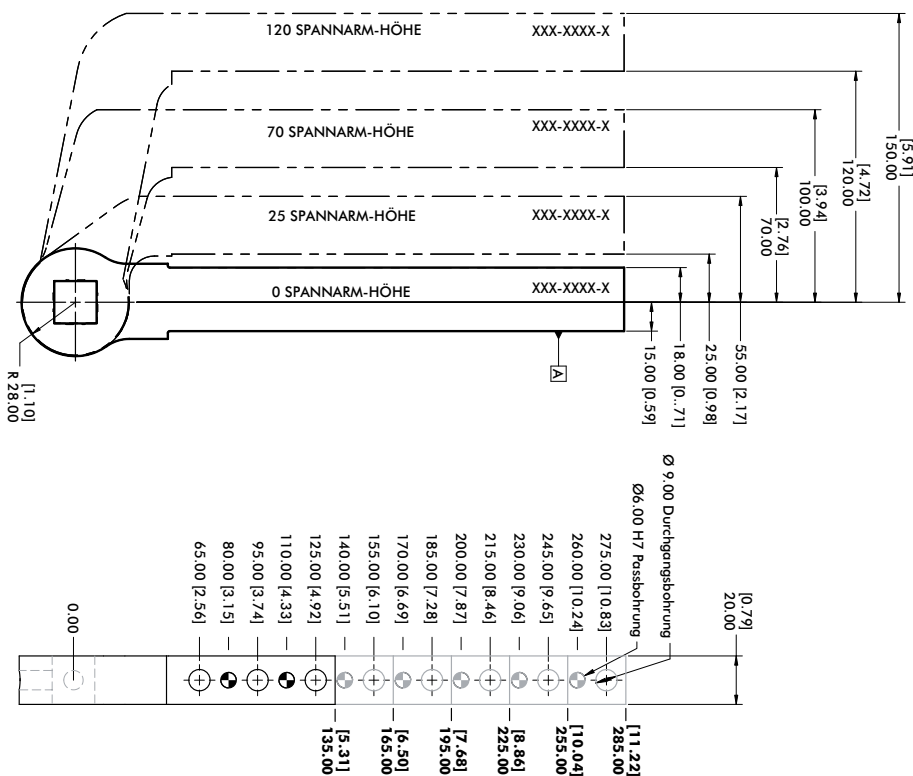

135mm [5.31"] Spannarm-Länge

Serie	Spannarm-Variante	Modell
120 Spannarm-Höhe	▲ 1543	B8JG-1543-1
70 Spannarm-Höhe	▲ 1531	B8JG-1531-1
25 Spannarm-Höhe	▲ 1519	B8JG-1519-1
0 Spannarm-Höhe	▲ 1507	B8JG-1507-1

165mm [6.50"] Spannarm-Länge

Serie	Spannarm-Variante	Modell
120 Spannarm-Höhe	▲ 1544	B8JG-1544-1
70 Spannarm-Höhe	▲ 1532	B8JG-1532-1
25 Spannarm-Höhe	▲ 1520	B8JG-1520-1
0 Spannarm-Höhe	▲ 1508	B8JG-1508-1

195mm [7.68"] Spannarm-Länge

Serie	Spannarm-Variante	Modell
120 Spannarm-Höhe	▲ 1545	B8JG-1545-1
70 Spannarm-Höhe	▲ 1533	B8JG-1533-1
25 Spannarm-Höhe	▲ 1521	B8JG-1521-1
0 Spannarm-Höhe	▲ 1509	B8JG-1509-1

225mm [8.86"] Spannarm-Länge

Serie	Spannarm-Variante	Modell
120 Spannarm-Höhe	▲ 1546	B8JG-1546-1
70 Spannarm-Höhe	▲ 1534	B8JG-1534-1
25 Spannarm-Höhe	▲ 1522	B8JG-1522-1
0 Spannarm-Höhe	▲ 1510	B8JG-1510-1

255mm [10.04"] Spannarm-Länge

Serie	Spannarm-Variante	Modell
120 Spannarm-Höhe	▲ 1547	B8JG-1547-1
70 Spannarm-Höhe	▲ 1535	B8JG-1535-1
25 Spannarm-Höhe	▲ 1523	B8JG-1523-1
0 Spannarm-Höhe	▲ 1511	B8JG-1511-1

285mm [11.22"] Spannarm-Länge

Serie	Spannarm-Variante	Modell
120 Spannarm-Höhe	▲ 1548	B8JG-1548-1
70 Spannarm-Höhe	▲ 1536	B8JG-1536-1
25 Spannarm-Höhe	▲ 1524	B8JG-1524-1
0 Spannarm-Höhe	▲ 1512	B8JG-1512-1

▲ Üblich in Nordamerika

(*) STANDARD-ARM

Maximaler Öffnungswinkel (in geschlossener Position, wie abgebildet)

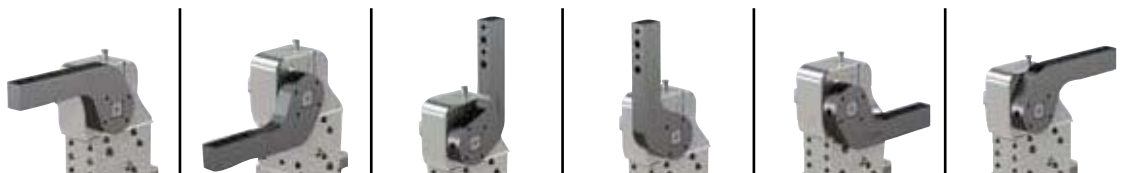

Spannarm-Varianten	135°	135°	100°	100°	N/A	N/A
1510-1512/1507-1509	135°	135°	100°	100°	N/A	N/A
1522-1524/1519-1521	135°	N/A	50°	130°	N/A	40°
1534-1536/1531-1533	115°	N/A	25°	135°	N/A	75°
1546-1548/1543-1545	110°	N/A	20°	135°	N/A	85°

52H-3E. 63mm für D0 Spannarmwelle

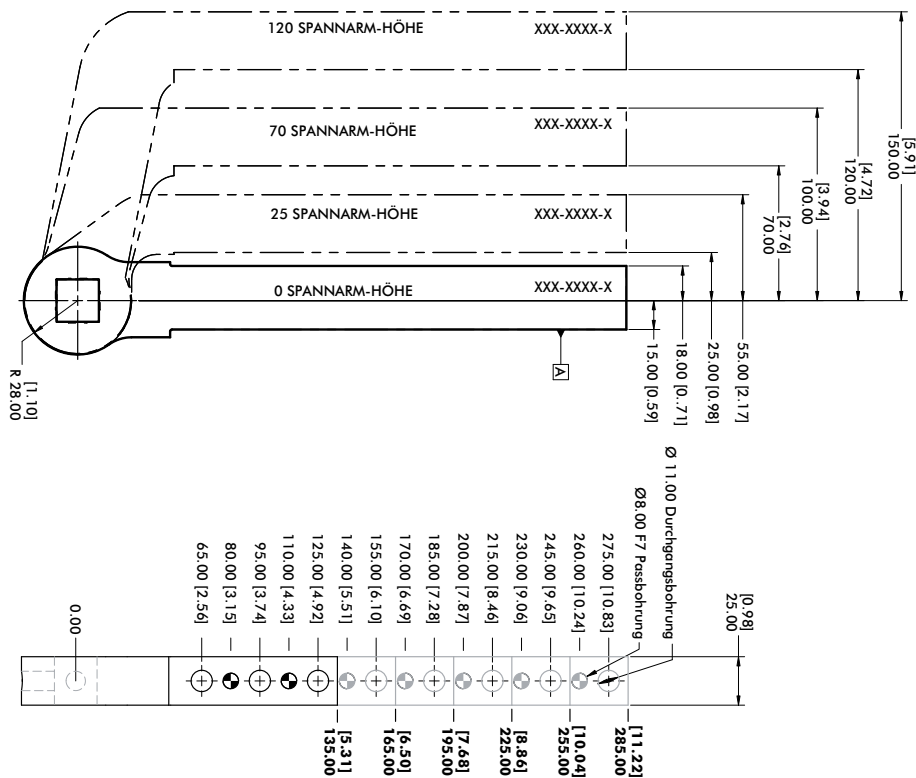

135mm [5.31"] Spannarm-Länge

Serie	Spannarm-Variante	Modell
120 Spannarm-Höhe	▲ • 1043	B8JG-1043-1
70 Spannarm-Höhe	▲ • 1031	B8JG-1031-1
25 Spannarm-Höhe	▲ • 1019	B8JG-1019-1
0 Spannarm-Höhe	▲ • 1007	B8JG-1007-1

165mm [6.50"] Spannarm-Länge

Serie	Spannarm-Variante	Modell
120 Spannarm-Höhe	▲ ⓘ 1044	B8JG-1044-1
70 Spannarm-Höhe	▲ • 1032	B8JG-1032-1
25 Spannarm-Höhe	▲ • 1020	B8JG-1020-1
0 Spannarm-Höhe	▲ • 1008	B8JG-1008-1

195mm [7.68"] Spannarm-Länge

Serie	Spannarm-Variante	Modell
120 Spannarm-Höhe	▲ ⓘ 1045	B8JG-1045-1
70 Spannarm-Höhe	▲ • 1033	B8JG-1033-1
25 Spannarm-Höhe	▲ ⓘ 1021	B8JG-1021-1
0 Spannarm-Höhe	▲ • 1009	B8JG-1009-1

225mm [8.86"] Spannarm-Länge

Serie	Spannarm-Variante	Modell
120 Spannarm-Höhe	▲ ⓘ 1046	B8JG-1046-1
70 Spannarm-Höhe	▲ • 1034	B8JG-1034-1
25 Spannarm-Höhe	▲ ⓘ 1022	B8JG-1022-1
0 Spannarm-Höhe	▲ ⓘ 1010	B8JG-1010-1

255mm [10.04"] Spannarm-Länge

Serie	Spannarm-Variante	Modell
120 Spannarm-Höhe	▲ ⓘ 1047	B8JG-1047-1
70 Spannarm-Höhe	▲ • 1035	B8JG-1035-1
25 Spannarm-Höhe	▲ ⓘ 1023	B8JG-1023-1
0 Spannarm-Höhe	▲ ⓘ 1011	B8JG-1011-1

285mm [11.22"] Spannarm-Länge

Serie	Spannarm-Variante	Modell
120 Spannarm-Höhe	▲ ⓘ 1048	B8JG-1048-1
70 Spannarm-Höhe	▲ ⓘ 1036	B8JG-1036-1
25 Spannarm-Höhe	▲ ⓘ 1024	B8JG-1024-1
0 Spannarm-Höhe	▲ ⓘ 1012	B8JG-1012-1

▲ Üblich in Nordamerika

(•) STANDARD-ARM

ⓘ KEIN STANDARD-ARM (längere Lieferzeiten)

Maximaler Öffnungswinkel (in geschlossener Position, wie abgebildet)

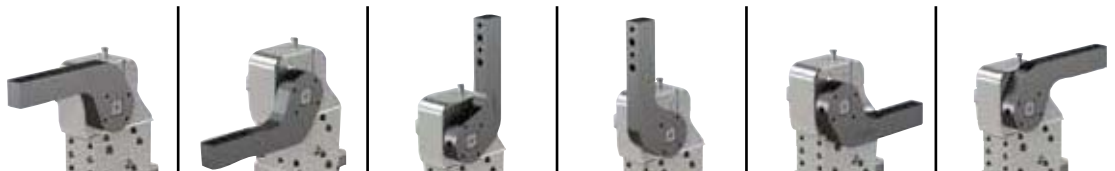

Spannarm-Varianten	1	2	3	4	5	6
1010-1012/1007-1009	135°	135°	100°	100°	N/A	N/A
1022-1024/1019-1021	135°	N/A	50°	130°	N/A	40°
1034-1036/1031-1033	115°	N/A	25°	135°	N/A	75°
1046-1048/1043-1045	110°	N/A	20°	135°	N/A	85°