

# ZAHNSTANGENSPELLER

## CARVER Spanner | Produktübersicht

### Produktmerkmale:

Diese stabilen Zahnstangenspanner sind sehr universell und aus hoch belastbarem, gehärtetem Stahl. Sie sind geeignet für alle Anwendungen, in denen hohe Haltekräfte von 5650N bis 27000N (1270 lbf bis 6000 lbf) erforderlich sind. Man kann zum Beispiel die Backen drehen und den Spanner für Zug oder Druck Anwendungen einsetzen.

Verfügbare Modelle: T321 Standard Ausladung, T285 große Ausladung, T186 kurze Ausladung, T290 medium- und T257 schwere Ausführung. Zusätzlich gibt es für die Standard- und schwere Ausführung Verbindungsstücke zum Verbinden von 2 Zahnstangen für extreme Spannweiten.

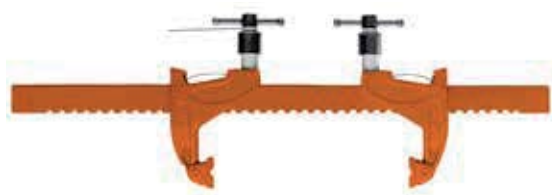

Modell	Für Zahnstangen-spanner	Gewicht [lbs.] kg
<b>186-13</b>	T186-... and T321-...	[1.54] 0,7
<b>290-13</b>	T285-... and T290-...	[2.87] 1,3

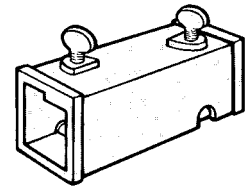

Verbindungsstück

### Technische Informationen | Haltekräfte

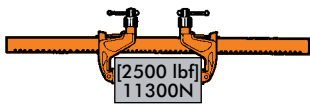
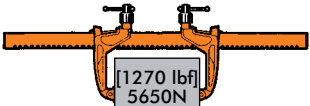
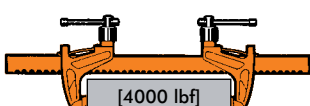
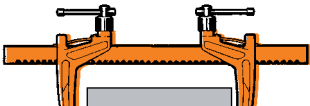
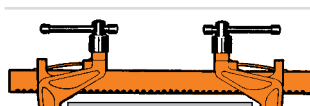
Haltekraft	Ausladung B1	Spannweite S		Spannweite S1		Modell	Spannschraube Ø	Gewicht [lbs.] kg	Bestehend aus:	
		min	max	min	max				1x	2x
 [2500 lbf] 11300N	[2.38] 60	[8.50] 215	[24] 600	[36] 900	[2.95] 75	[26.8] 680	M12	[7.50] 3,4	186-24-1	186-2
			[39] 990		[39] 990	186-36-1				
 [1270 lbf] 5650N	[4.7] 120	[5.50] 140	[24] 600	[36] 900	[3.15] 80	[27.2] 690	M12	[7.70] 3,5	186-24-1	321-2
			[39] 990		[39.4] 1000	[9.00] 4,5		186-36-1		
			[60] 1500		[63] 1600	[13.00] 5,9		186-60-1		
 [4000 lbf] 18000N	[3.5] 90	[10.00] 250	[36] 900	[60] 1500	[4.72] 120	[36.9] 1005	M16	[20.50] 10,5	290-36-1	290-2
			[84] 2100		[63.8] 1620	[28.50] 14,0		290-60-1		
			[87.4] 2220		[87.4] 2220	[36.50] 18,0		290-84-1		
 [2000 lbf] 9000N	[8.0] 200	[6.00] 150	[36] 900	[60] 1500	[4.72] 120	[42.7] 1085	M16	[24.50] 10,5	290-36-1	285-2
			[84] 2100		[66.93] 1700	[32.50] 15,0		290-60-1		
			[90.6] 2300		[90.6] 2300	[40.50] 19,0		290-84-1		
 [6000 lbf] 27000N	[4.5] 115	[12.00] 305	[84] 2100	[5.90] 150	[86.6] 2200	ⓘ T257-84	M20	[61.00] 27,2	257-84-1	257-2

ⓘ Auf Anfrage

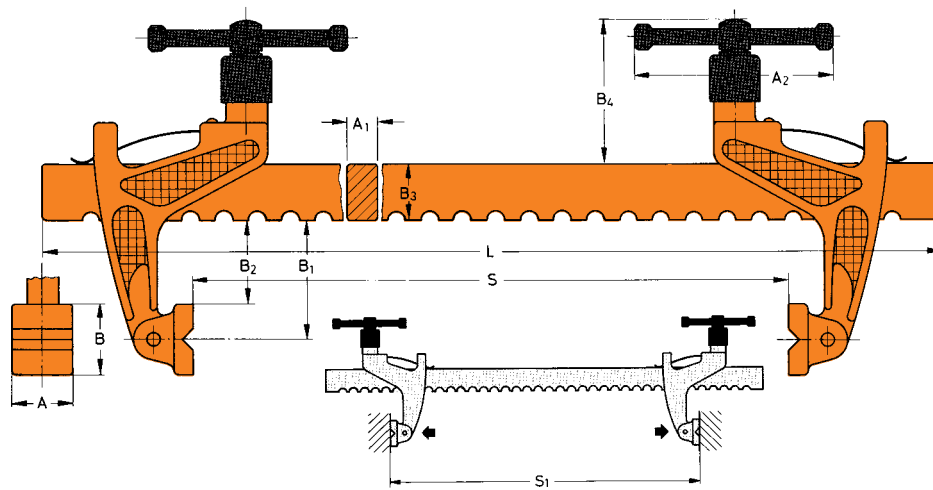

Modell	[inch] mm							
	A	A1	A2	B	B2	B3	B4	L
<b>T186-24</b>								[28] 710
<b>T186-36</b>	[0.98] 25	[0.47] 12	[2.99] 76	[1.26] 32	[1.73] 44	[1.18] 30	[2.99] 76	[40.2] 1020
<b>T321-24</b>								[28] 710
<b>T321-36</b>	[0.98] 25	[0.47] 12	[2.99] 76	[1.26] 32	[4.09] 104	[1.18] 30	[2.99] 76	[40.2] 1020
<b>T321-60</b>								[64] 1625
<b>T290-36</b>								[42.1] 1070
① <b>T290-60</b>	[1.50] 38	[0.79] 20	[5.51] 140	[2.00] 51	[2.56] 65	[1.57] 40	[4.13] 105	[66.5] 1690
① <b>T290-84</b>								[90.2] 2290
<b>T285-36</b>								[42.1] 1070
① <b>T285-60</b>	[1.50] 38	[0.79] 20	[5.51] 140	[2.00] 51	[7.09] 180	[1.57] 40	[4.13] 105	[66.5] 1690
① <b>T285-84</b>								[90.2] 2290
① <b>T257-84</b>	[2.00] 51	[0.87] 22	[7.36] 187	[2.50] 63,5	[3.27] 83	[2.05] 52	[5.00] 127	[91.9] 2335

① Auf Anfrage