

Artikelbeschreibung/Produktabbildungen



Beschreibung

**Werkstoff:**  
Automatenstahl brüniert.

Zeichnungen

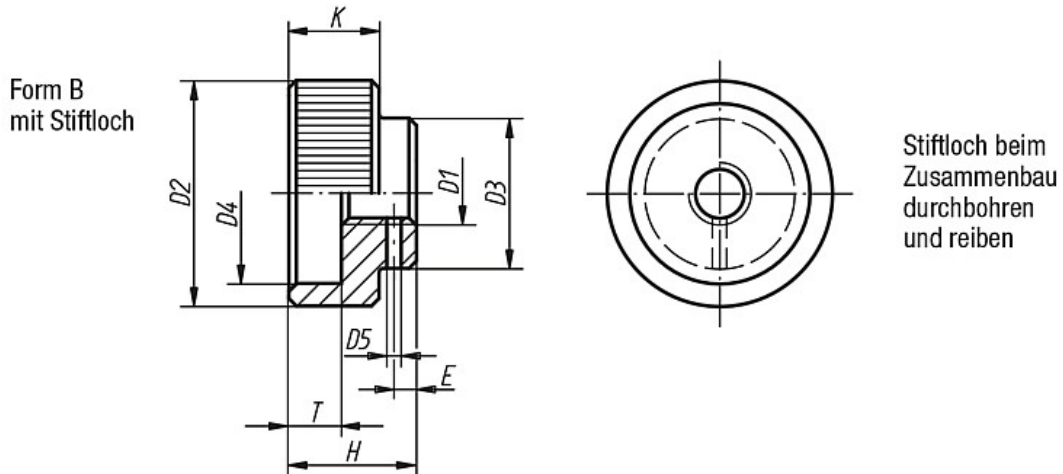

Artikelübersicht

Bestellnummer	Form	Material	D1	D2	D3	D4	D5 vorgebohrt	E	H	K	T	passender Zylinderstift ISO 2338	Gewicht ca. g
K0137.205	B	Stahl	M5	20	14	15	1,4	2,5	12	8	5	1,5 m6 x 14	16
K0137.206	B	Stahl	M6	24	16	18	1,4	2,5	14	10	6	1,5 m6 x 16	27
K0137.208	B	Stahl	M8	30	20	24	1,9	3	17	12	7	2 m6 x 20	50
K0137.210	B	Stahl	M10	36	28	30	2,9	4	20	14	8	3 m6 x 28	83
K0137.212	B	Stahl	M12	40	32	34	3,9	4	24	16	10	4 m6 x 32	123