

RFE SERIES

Feed Escapements | Features and Benefits | How To Order | Technical Specifications

Features:

- Sequential Part feeding with automatic finger locking mechanism
- Non-rotating square shaft maintains proper finger alignment
- Sealed design with adjustable retract stops
- Only one finger can be retracted at any time
- Unit can be mounted using top, bottom or face surface

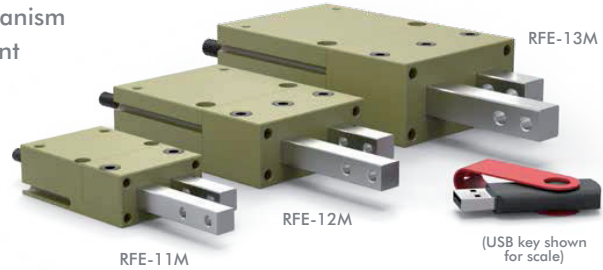

Applications:

- Part separation, part staging
- Conveying timing operations

How To Order

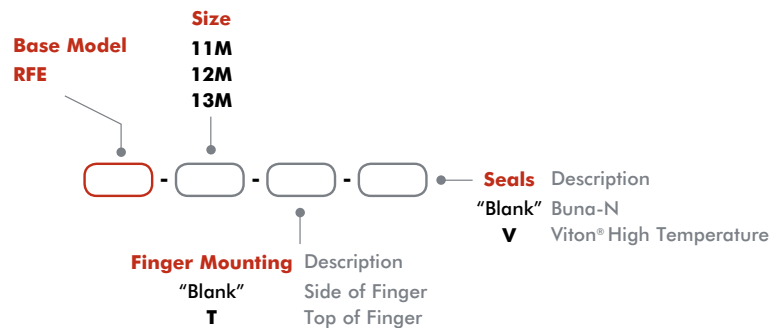

Accessories

Sensor Accessories	Model Numbers	Part Number	Qty/Unit
NPN Hall Effect Sensor with Quick Disconnect*	All Models	OHSN-017	1-2
PNP Hall Effect Sensor with Quick Disconnect*	All Models	OHSP-017	1-2
Quick Disconnect 2 Meter Cable Length*	All Models	CABL-010	1-2
Quick Disconnect 5 Meter Cable Length*	All Models	CABL-013	1-2

Pneumatic Accessories	Model Numbers	Part Number	Qty/Unit
M5 Adjustable Flow Control	All Models	VLVF-008	1-2

*Sensor and cable sold separately.

Specifications

Specifications	Units	11M	12M	13M
Thrust Force @ Maximun PSI	N [lbs]	111 [25]	222 [50]	400 [90]
Stroke	mm [in]	15.88 [0.625]	25.40 [1.000]	31.75 [1.250]
Stroke Adjustability	mm [in]	11 [0.44]	19 [0.75]	19 [0.75]
Weight	kg [lb]	0.15 [0.33]	0.39 [0.85]	0.83 [1.84]
Pressure Range	bar [psi]	3-7 [40-100]		
Cylinder Bore Ø	mm [in]	14.30 [0.563]	20 [0.787]	27 [1.063]
Rod Ø	mm [in]	6.35 [0.250]	7.95 [0.313]	9.52 [0.375]
Displacement	cm³ [in³]	2.6 [0.156]	8.0 [0.487]	18.2 [1.108]
Temperature Range (Buna-N seals)	°C [°F]	-35°~80° [-30°~180°]		
Temperature Range (Viton® seals)	°C [°F]	-30°~150° [-20°~300°]		
Actuation	sec	0.40	0.60	0.70
Parts Escaped per Minute		150	100	85
Valve to Actuate		4-way, 2-position		

Dimensions and technical information are subject to change without notice

RFE-11M

Feed Escapements | Dimensions and Technical Specifications

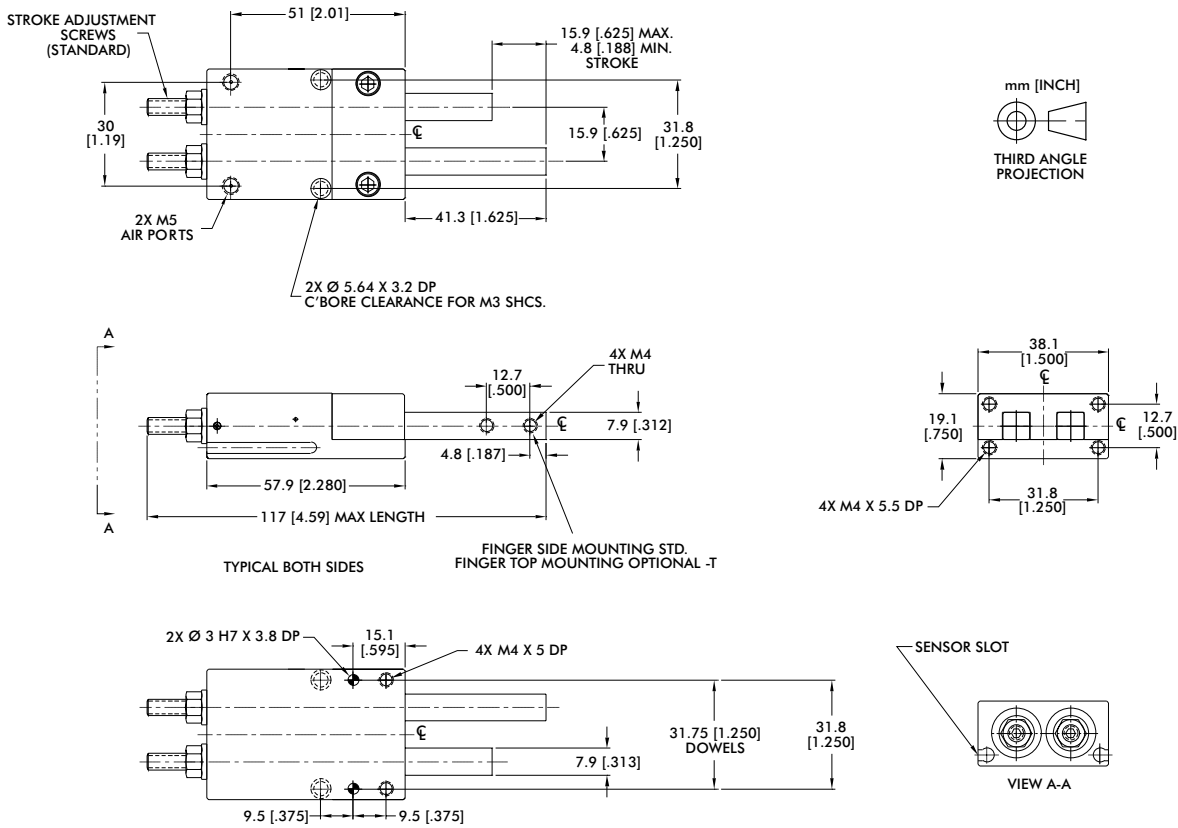

Seal Repair Kits	Order #
Buna-N Seal Repair Kit	SLKT-110
Viton® Seal Repair Kit	SLKT-110V

Loading Information

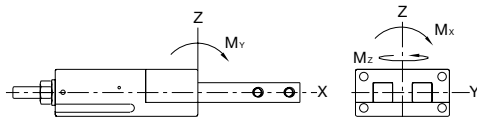

Cylinder Thrust Force

RFE-11M	Static
Maximum Moment M_x	6 Nm [50 in-lbs]
Maximum Moment M_y	6 Nm [50 in-lbs]
Maximum Moment M_z	6 Nm [50 in-lbs]

RFE-11M	Static
Thrust Force @ 7 bar [100psi]	111 N [25 lbs]
Thrust Force @ 5.5 bar [80 psi]	88 N [25 lbs]
Thrust Force @ 4 bar [60 psi]	66 N [15 lbs]
Thrust Force @ 2.7 bar [40 psi]	44 N [10 lbs]
Thrust Force @ 1.4 bar [20 psi]	22 N [5 lbs]

Dimensions and technical information are subject to change without notice

RFE-12M

Feed Escapements | Dimensions and Technical Specifications

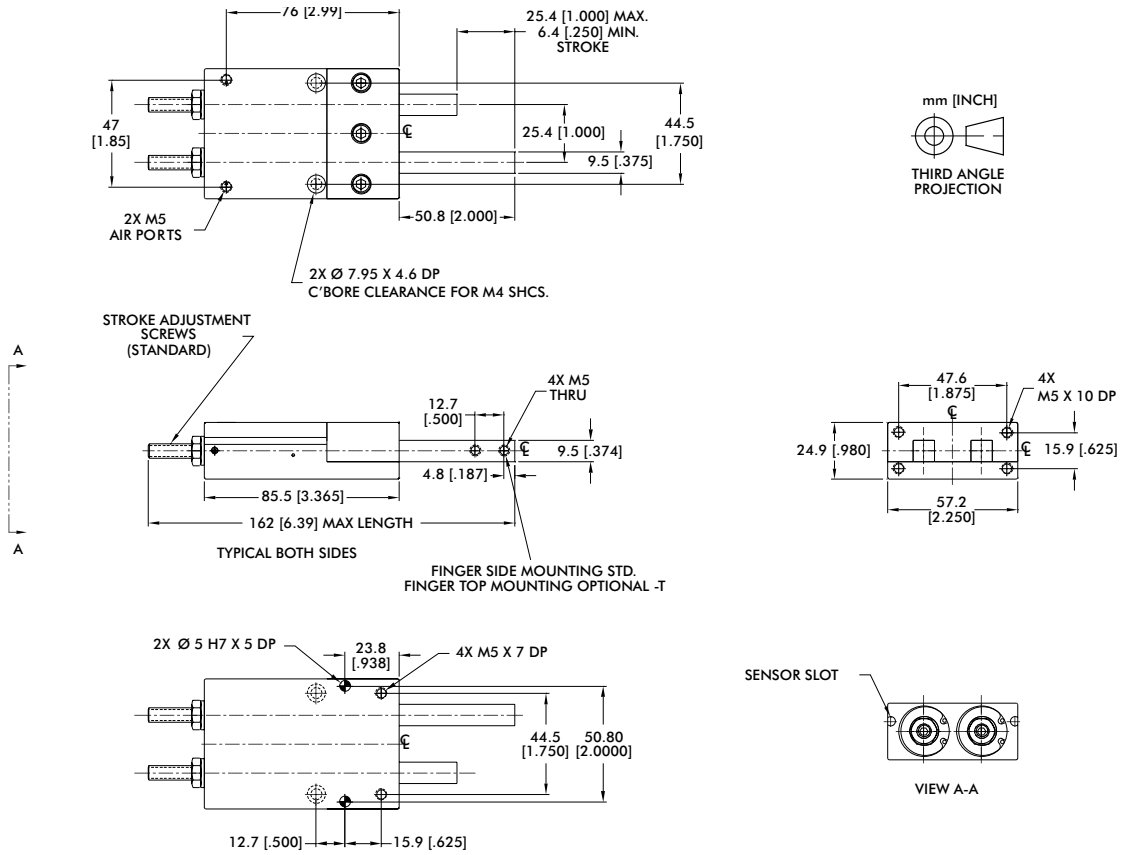

Seal Repair Kits	Order #
Buna-N Seal Repair Kit	SLKT-111
Viton® Seal Repair Kit	SLKT-111V

Loading Information

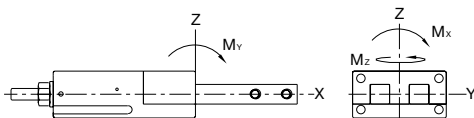

RFE-12M	Static
Maximum Moment M_x	17 Nm [150 in-lbs]
Maximum Moment M_y	17 Nm [150 in-lbs]
Maximum Moment M_z	17 Nm [150 in-lbs]

Cylinder Thrust Force

RFE-12M	Static
Thrust Force @ 7 bar [100psi]	216 N [50 lbs]
Thrust Force @ 5.5 bar [80 psi]	173 N [40 lbs]
Thrust Force @ 4 bar [60 psi]	130 N [30 lbs]
Thrust Force @ 2.7 bar [40 psi]	86 N [20 lbs]
Thrust Force @ 1.4 bar [20 psi]	43 N [10 lbs]

Dimensions and technical information are subject to change without notice

RFE-13M

Feed Escapements | Dimensions and Technical Specifications

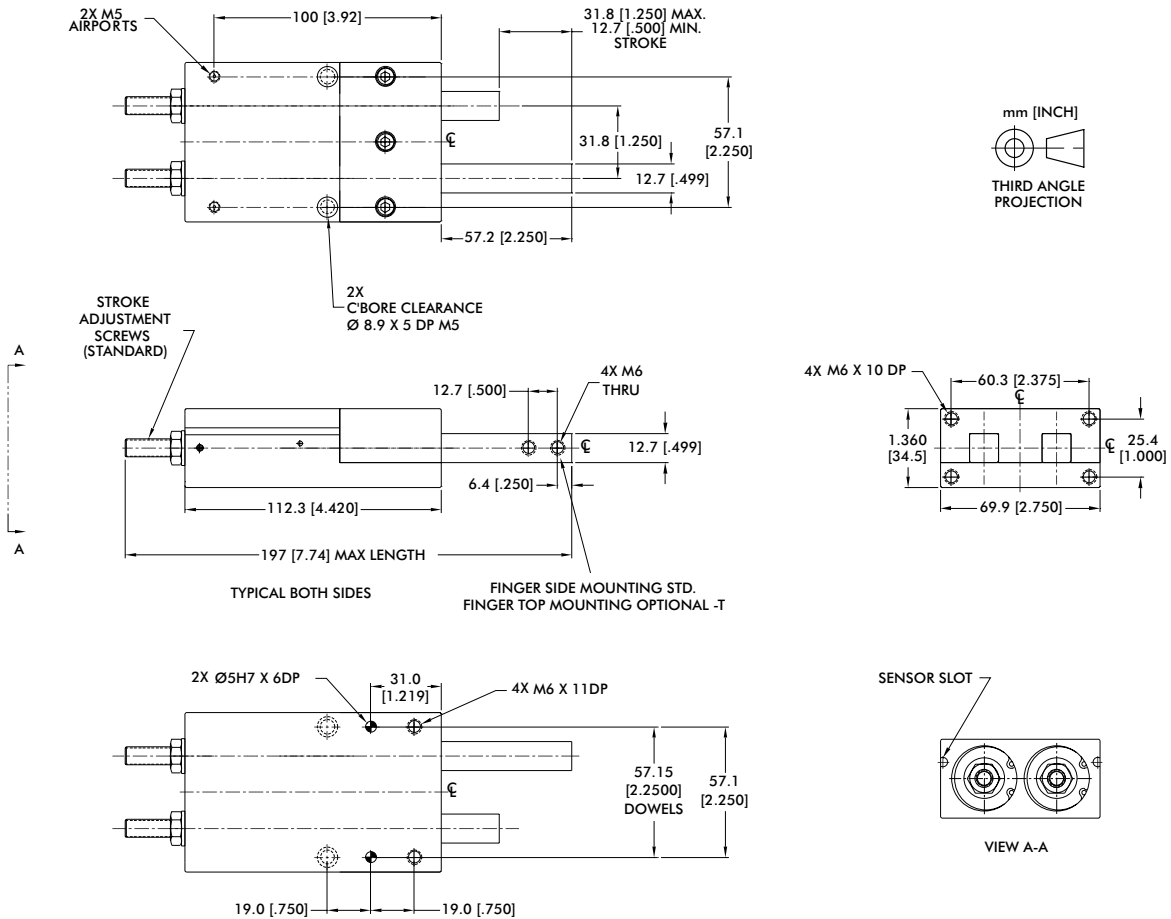

Seal Repair Kits	Order #
Buna-N Seal Repair Kit	SLKT-112
Viton® Seal Repair Kit	SLKT-112V

Loading Information

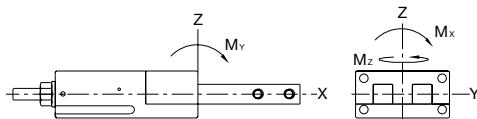

RFE-13M	Static
Maximum Moment M_x	28 Nm [250 in-lbs]
Maximum Moment M_y	28 Nm [250 in-lbs]
Maximum Moment M_z	28 Nm [250 in-lbs]

Cylinder Thrust Force

RFE-13M	Static
Thrust Force @ 7 bar [100psi]	394 N [88 lbs]
Thrust Force @ 5.5 bar [80 psi]	315 N [71 lbs]
Thrust Force @ 4 bar [60 psi]	236 N [53 lbs]
Thrust Force @ 2.7 bar [40 psi]	157 N [35 lbs]
Thrust Force @ 1.4 bar [20 psi]	78 N [17 lbs]

Dimensions and technical information are subject to change without notice