

RR LIGHT-DUTY SERIES

Rotary Actuators | Features and Benefits | How To Order

Features:

- Ultra-thin profile for tight space applications
- Preloaded bearings for high repeatability rotary actuation
- Zero backlash and slip fit dowel pins for precision applications
- Built-in adjustable hard-stops
- Optional manifold eliminates twisted airlines
- **CR-** Clean room option or for use in harsh environment applications

Applications:

- Precision rotary positioning
- Medical applications
- OEM machines



(USB key shown for scale)

How To Order

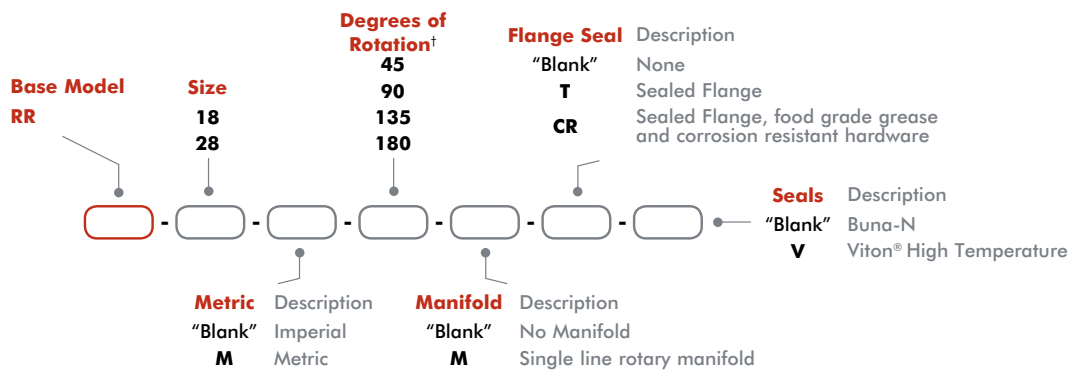

†Consult factory for intermediate degrees of rotation.

Accessories

Sensor Accessories	Model Numbers	Part Number	Qty/Unit
Sensor Mounting Kit (mounts 2 sensors)	All Models	OSMK-024	1
NPN Inductive Sensor with Quick Disconnect*	All Models	OISN-014	1-2
PNP Inductive Sensor with Quick Disconnect*	All Models	OISP-014	1-2
Quick Disconnect 2 Meter Cable Length*	All Models	CABL-010	1-2
Quick Disconnect 5 Meter Cable Length*	All Models	CABL-013	1-2

Pneumatic Accessories	Model Numbers	Part Number	Qty/Unit
M3 Plumbing Fitting Push-In for 3mm OD Tube	All Models	PLFT-021	2
M3 Plumbing Fitting Barb for 2mm ID Tube	All Models	PLFT-022	2
#10-32 Flow Control (Imperial)	All Models	VLVF-007	2
M5 Flow Control	All Models	VLVF-008	2

*Sensor and cable sold separately.

Dimensions and technical information are subject to change without notice

RR LIGHT-DUTY SERIES

Rotary Actuators | Technical Specifications

Specifications	Units	18	28
Maximum Payload	kg [lb]	0.45 [1.0]	1.36 [3.0]
Maximum Payload Inertia	Nm sec ² [in-lbs sec ²]	0.000181 [0.0016]	0.001255 [0.0111]
Maximum Rotation		180°	
Maximum Torque Mid-Stroke @ 100psi/7 bar	Nm [lbs-in]	0.7 [6.5]	2.5 [22]
Maximum Torque End Stroke @ 100psi/7 bar			
Pitch Diameter of Pinion	mm [in]	8.46 [0.333]	12.7 [0.50]
Weight	kg [lb]	0.22 [0.48]	0.65 [1.44]
Pressure Range	bar [psi]	2-7 [30-100]	
Ingress Protection Class (IP)		IP66	
Displacement (180°)	cm ³ [in ³]	3.37 [0.205]	11.4 [0.69]
Temperature Range (Buna-N seals)	°C [°F]	-35°~80° [-30°~180°]	
Temperature Range (Viton® seals)	°C [°F]	-30°~150° [-20°~300°]	
Actuation Time (180° @ 100psi/7 bar)	sec	0.30	0.35
Actuation Time (90° @ 100psi/7 bar)	sec	0.25	0.30
End Stop Repeatability		±0.02°	
End Stop Adjustability		23°	
Over Travel (each end)		4°	8°
Valve required to actuate		4-way, 2-position	

Dimensions and technical information are subject to change without notice

RR-18

Rotary Actuators | Dimensions and Technical Specifications

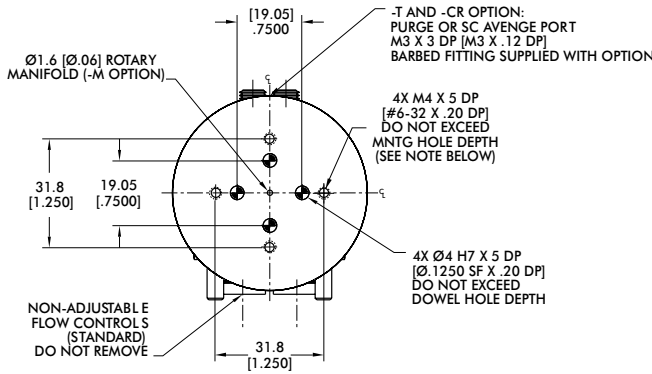

UNIT SHOWN IN 0° POSITION ROTATED FULLY CW

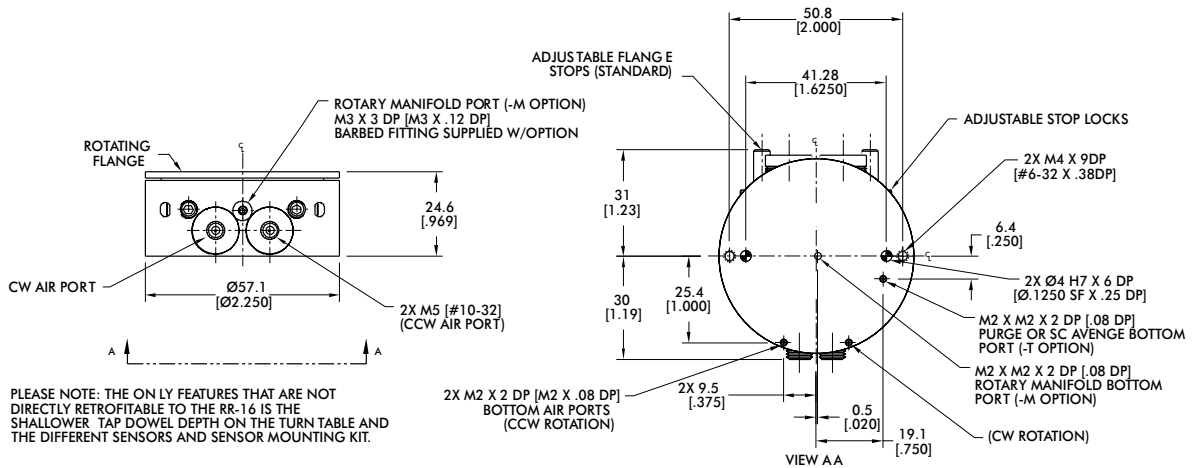

Seal Repair Kits	Order #
Buna-N Seal Repair Kit	SLKT-173
Viton® Seal Repair Kit	SLKT-173V
Viton® Bottom Air Port Manifold Seal Kit	SLKT-174V

Loading Information

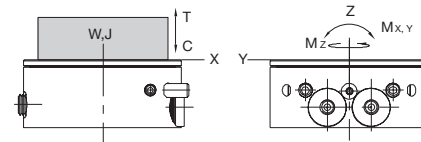

RR-18 Loading Information	Static
Maximum Tensile T	222 N [50 lbs]
Maximum Compressive C	1112 N [250 lbs]
Maximum Moment M_x	11 Nm [100 in-lbs]
Maximum Moment M_y	11 Nm [100 in-lbs]
Maximum Payload W	0.45 kg [1 lbs]
Maximum Inertia J	0.000181 N-m-sec ² [0.0016 in-lbs-sec ²]

Note: Higher payloads and inertia possible with external shocks and stops.

Dimensions and technical information are subject to change without notice

RR-28

Rotary Actuators | Dimensions and Technical Specifications

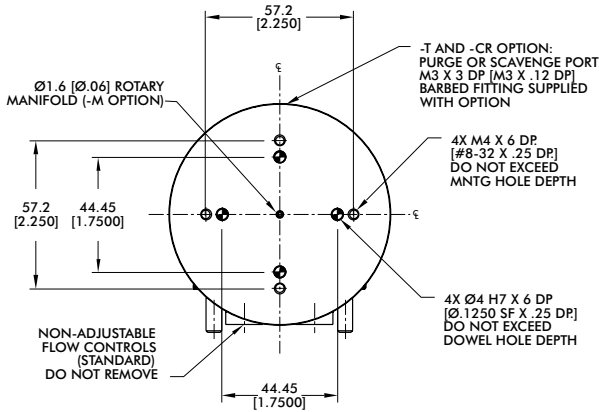

UNIT SHOWN IN 0° POSITION ROTATED FULLY CW

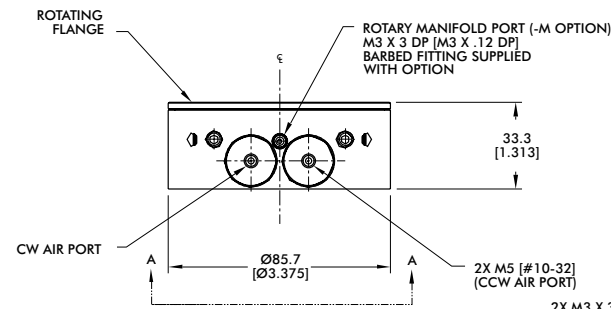
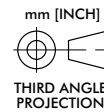

PLEASE NOTE: THE ONLY FEATURES THAT ARE NOT DIRECTLY RETROFITTABLE TO THE RR-26 IS THE DIFFERENT SENSORS & SENSOR MOUNTING KIT.

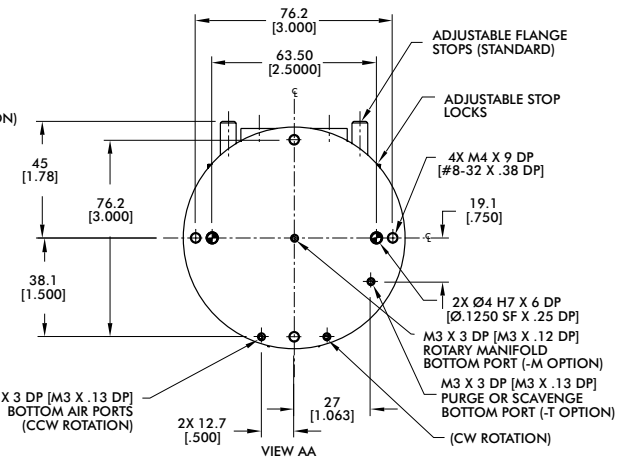

Seal Repair Kits	Order #
Buna-N Seal Repair Kit	SLKT-175
Viton® Seal Repair Kit	SLKT-175V
Viton® Bottom Air Port Manifold Seal Kit	SLKT-176V

Loading Information

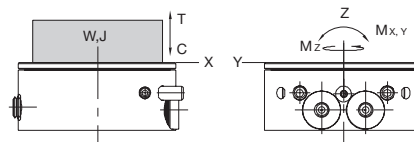

RR-28 Loading Information	Static
Maximum Tensile T	334 N [75 lbs]
Maximum Compressive C	2224 N [500 lbs]
Maximum Moment M_x	28 Nm [250 in-lbs]
Maximum Moment M_y	28 Nm [250 in-lbs]
Maximum Payload W	1.36 kg [3 lbs]
Maximum Inertia J	0.001255 N-m-sec ² [0.0111 in-lbs-sec ²]

Note: Higher payloads and inertia possible with external shocks and stops.

Dimensions and technical information are subject to change without notice