

EH 24620.

Kreuzgriffe

DIN 6335

Grauguss

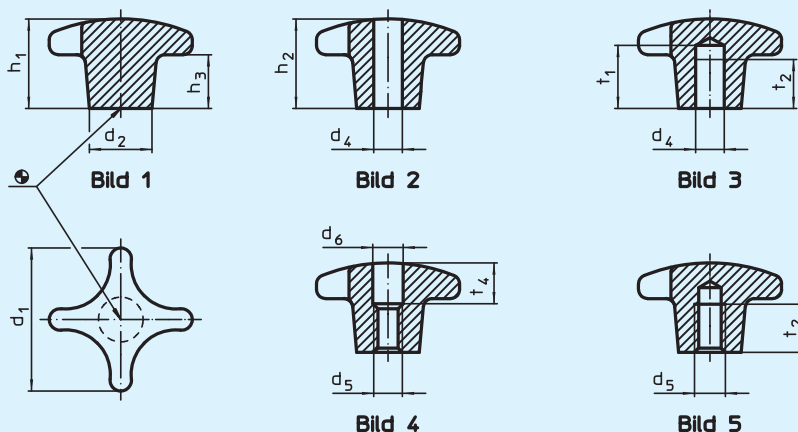

Werkstoff:

- Grauguss GG 20, blank

Hinweis:

Sandgestrahlt oder gerommt.

Sonderausführungen mit anderer Bohrung oder oberflächenveredelt werden auf Bestellung gefertigt.

Best.-Nr.	Ausführung	d ₁	d ₂	d ₄ H7	d ₅	d ₆	h ₁	h ₂	h ₃	t ₁	t ₂	t ₄	g
24620.0032	Rohteil,	32	12	-	-	-	21	-	10	-	-	-	38
24620.0040	Form A	40	14	-	-	-	26	-	14	-	-	-	69
24620.0050	(Bild 1)	50	18	-	-	-	34	-	20	-	-	-	115
24620.0063		63	20	-	-	-	42	-	25	-	-	-	228
24620.0080		80	25	-	-	-	52	-	30	-	-	-	415
24620.0090		100	32	-	-	-	65	-	38	-	-	-	855
24620.0132	mit glatter Bohrung,	32	12	6	-	-	20	-	-	-	-	-	34
24620.0140	durchgehende,	40	14	8	-	-	25	-	-	-	-	-	59
24620.0150	Form B	50	18	10	-	-	32	-	-	-	-	-	95
24620.0163	(Bild 2)	63	20	12	-	-	40	-	-	-	-	-	171
24620.0180		80	25	16	-	-	50	-	-	-	-	-	338
24620.0190		100	32	20	-	-	63	-	-	-	-	-	709
24620.0232	mit glattem Sackloch,	32	12	6	-	-	20	-	15	12	-	-	36
24620.0240	Form C	40	14	8	-	-	25	-	18	15	-	-	61
24620.0250	(Bild 3)	50	18	10	-	-	32	-	21	18	-	-	99
24620.0263		63	20	12	-	-	40	-	25	22	-	-	200
24620.0280		80	25	16	-	-	50	-	32	28	-	-	380
24620.0290		100	32	20	-	-	63	-	40	36	-	-	706
24620.0332	mit Gewinde,	32	12	-	M 6	6,4	-	20	-	-	-	10	34
24620.0340	aufgebohrt,	40	14	-	M 8	8,4	-	25	-	-	-	12	60
24620.0350	Form D	50	18	-	M 10	10,5	-	32	-	-	-	16	95
24620.0363	(Bild 4)	63	20	-	M 12	13,0	-	40	-	-	-	20	191
24620.0380		80	25	-	M 16	17,0	-	50	-	-	-	30	339
24620.0390		100	32	-	M 20	21,0	-	63	-	-	-	38	704
24620.0432	mit Gewindegewinde,	32	12	-	M 6	-	-	20	-	-	12	-	35
24620.0440	Form E	40	14	-	M 8	-	-	25	-	-	15	-	63
24620.0450	(Bild 5)	50	18	-	M 10	-	-	32	-	-	18	-	103
24620.0463		63	20	-	M 12	-	-	40	-	-	22	-	205
24620.0480		80	25	-	M 16	-	-	50	-	-	28	-	359
24620.0490		100	32	-	M 20	-	-	63	-	-	36	-	730