

95W-1

Electric Smart Guides/Lifters | How to Order

95W-1 01 02 10 60

Motor Connection	Description
00	Straight, without Drive
01	Straight, Rear Connections
02	Straight, Connections on Right
03	Straight, Connections on Left
10	Redirected, without Drive
11	Redirected, Rear Connections
12	Redirected, Connections on Right
13	Redirected, Connections on Left

Motor	Description
01	Servo Drive, Decentral 400 V
02	Servo Drive, Decentral 48 V

Stroke	Description
60	0-60 mm Stroke, Standard

Mounting Plate	Description
10	Mounting Plate, Standard
60	Mounting Plate, Standard

95W-111021060

95W-101011060

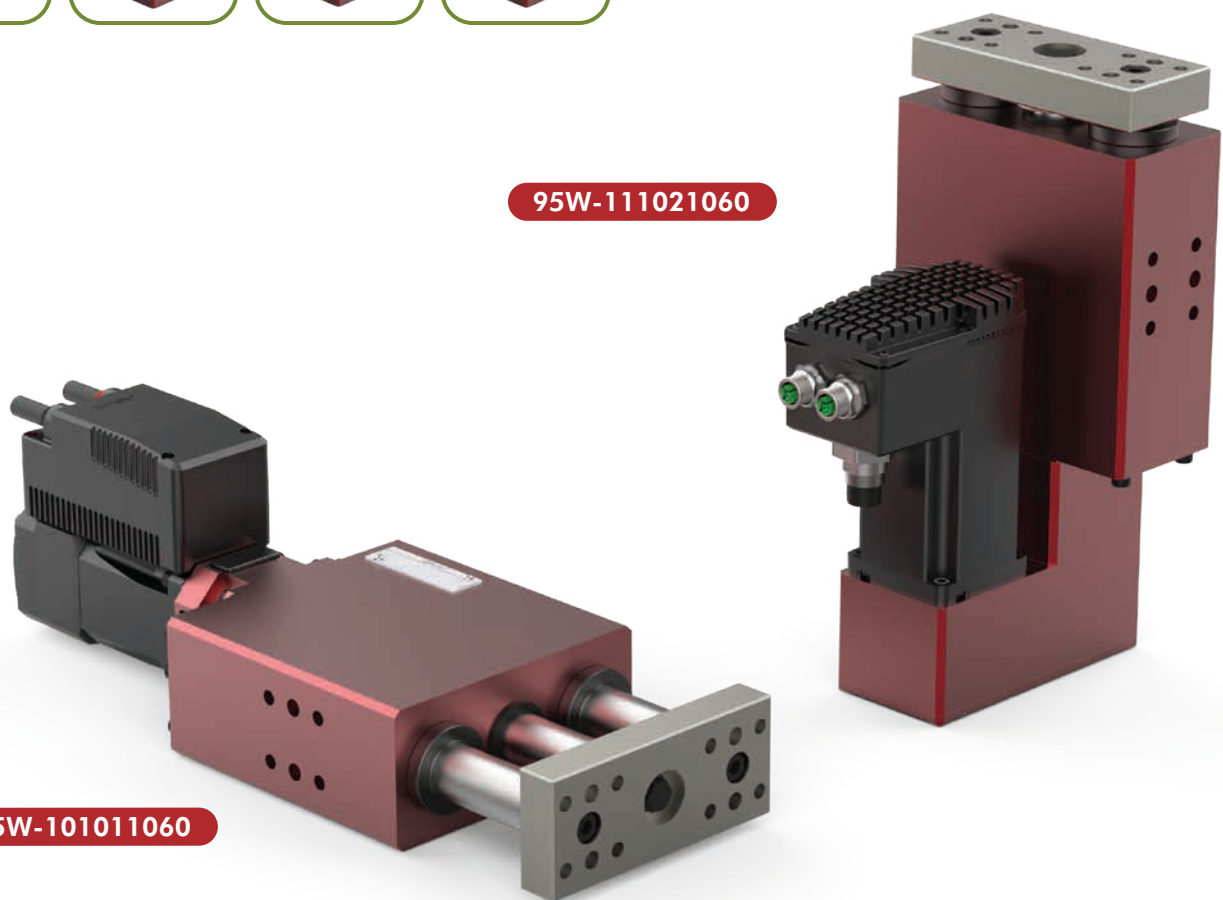

95W-10.011060 [400 V]

Electric Smart Guides/Lifters | Dimensions | Technical Specifications

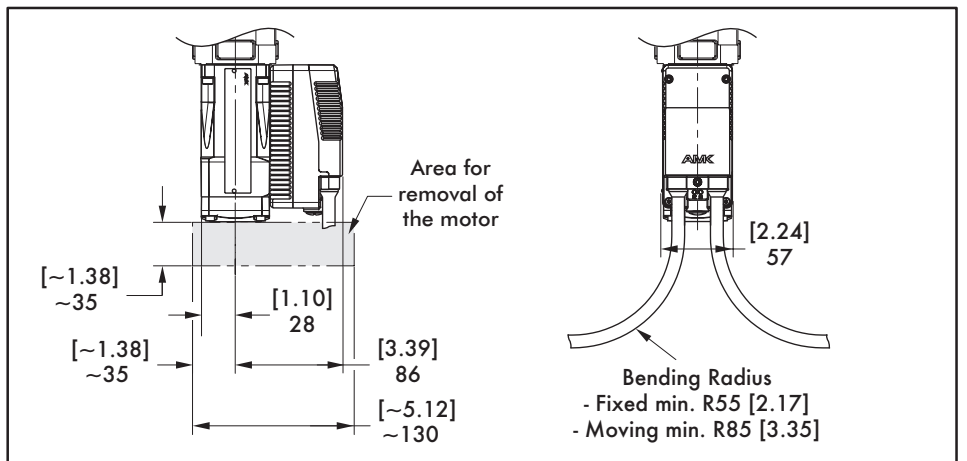
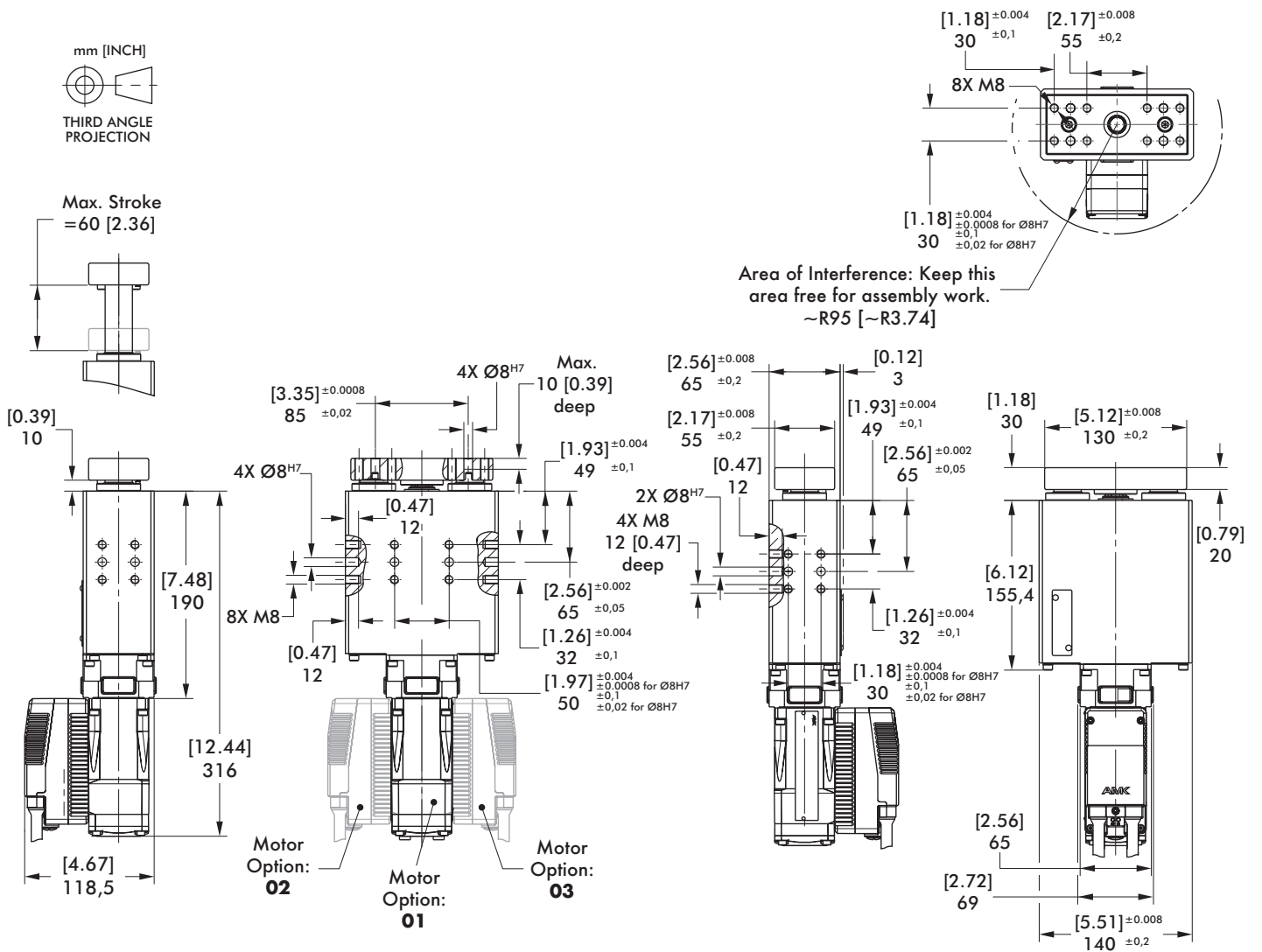

Base Model	Stroke mm [in]	Lifting Force N [lbf]	Holding Force N [lbf]	Speed Max. mm/s [in/s]	Weight Kg [lbs]
95W-10.011060	[0-2.36] 0-60	[225] 1000	[225] 1000	[2.36] 60	[16.31] 7,4

95W-11.011060 [48 V]

Electric Smart Guides/Lifters | Dimensions | Technical Specifications

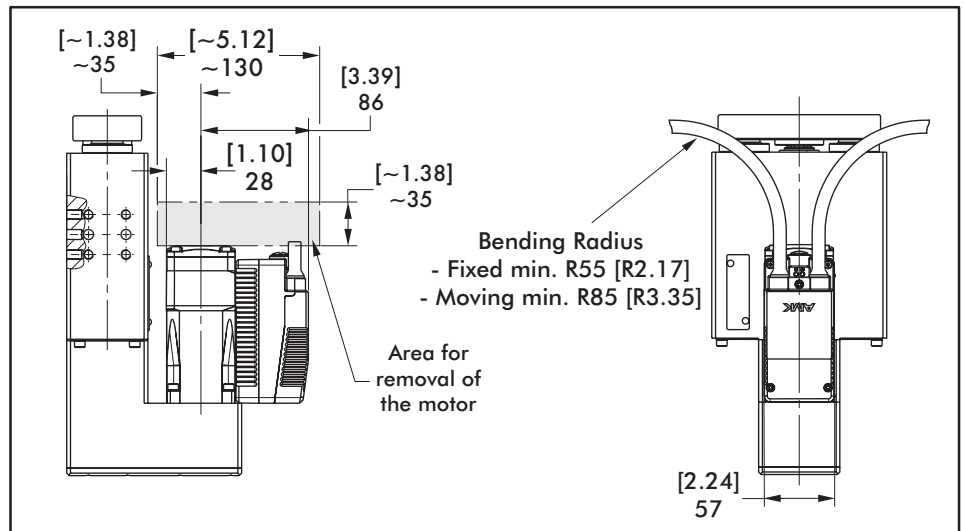
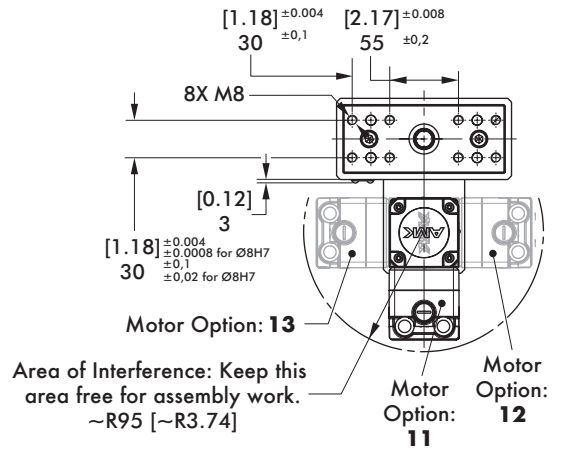
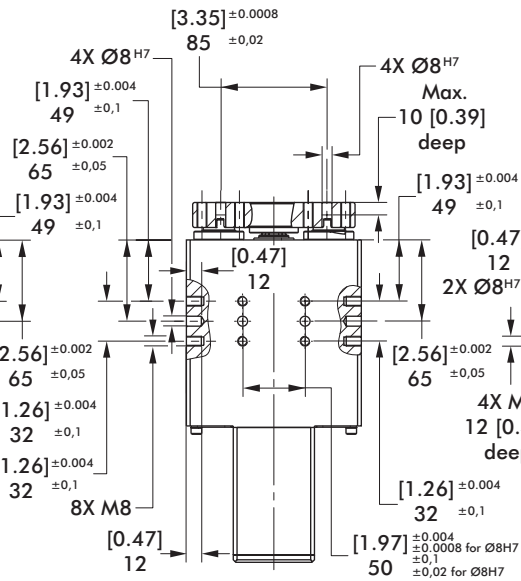
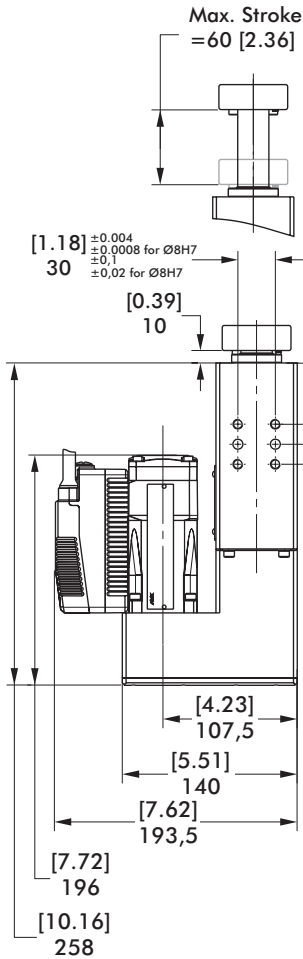
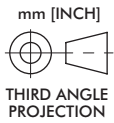

Base Model	Stroke mm [in]	Lifting Force N [lbf]	Holding Force N [lbf]	Speed Max. mm/s [in/s]	Weight Kg [lbs]
95W-11.011060	[0-2.36] 0-60	[225] 1000	[225] 1000	[2.36] 60	[20.72] 9,4

